

Schneider Electric Busway

I-LINE® II

From 630A to 6300A

[100%
IEC61439-6]

Catalogue
2016-2017

Complete solution
also includes:
Medium power busway
(100A-800A)
Lighting busway
(20A-40A)



Schneider
Electric

Contents

Introduction	3
Schneider busway is evolving to meet your needs	3
Schneider busway distribution system	4
Schneider busway, in total harmony with the environment	6
From the transportation to the distribution, Schneider busway is the core of your installation	8
Schneider busway, a display of advantages	10
Schneider busway is adapted for all types of building	12
Schneider busway enjoys reliable quality with complete certification	16
With the Schneider busway tools and services, let us compose your project	17
Presentation and Description	19
Panorama of Schneider Busway Range	20
I-LINE II from 630 to 6300A	24
General	26
Straight Length	28
Fitting	29
Supports and Fixings	31
Special Fitting	32
Plug-in Unit	33
Catalogue Numbers and Dimensions	35
Catalogue Number Coding	36
<i>I-Line II Copper Busway</i>	
Straight Length	38
Straight Length Components	39
Elbow	41
Flanged End	51
Cable Tap Box	53
Feed Unit for Dry Type Transformer	54
Support and Fixings	56
<i>I-Line II Copper Contact Busway</i>	
Straight Length	59
Straight Length Components	60
Elbow	62
Flanged End	67
Cable Tap Box	69
Feed Unit for Dry Type Transformer	70
Support and Fixings	72
<i>Plug-in Unit</i>	74
Design Guide	79
Characteristics	80
Design with I-LINE II Busbar Trunking System	82
Harmonic Current	86
Fire Resistance	88
Measurement and Metering	90
iBusway Solution	92
Direct Current	96
Installation Guide	97
Layout Advice	98
Rising Main	101
Reception, Handling and Storage	103
Testing and Commissioning	105
Maintenance	109
Suggested Specifications	111
Busbar Trunking System	112

*cover – Busway application in Data Center

Schneider busway is evolving to meet your needs



More than 70,000 km of Schneider busbar trunking has been sold around the world.

Schneider busway on its second world tour

- More than 50 years of experience, with hundreds of thousands of installations in operation throughout the world.
- Full type test certification (IEC61439) for each and every ampere rating of busway.

A total coordination with the Schneider Electric system

Busway is a part of a comprehensive offering of Schneider Electric products designed to operate together. This concept covers all low and medium voltage electrical distribution components. The result is an optimised electrical installation with even higher performance through full electrical, mechanical and communication compatibility.

With the new range, you get a complete, tested distribution solution that complies with standards. It is perfectly suited to traditional applications (factories, warehouses, etc.) and to the distribution of electrical power from the incoming transformer on through to all types of loads in offices, commercial premises, laboratories, etc.

Schneider Busway Factories

Schneider Electric assures you on the product quality in accordance with our global standards irrespective of the Busway products originating from any Schneider factory worldwide. We certify the product design and quality meet the exact same standards in both Schneider Electric Facilities.

Dijon Factory was set up in 1972, manufacturing Canalis Busbar trunking system, ISO 9001 and ISO 14001 certified.



Canlis Factory, Dijon, France

I-LINE busbar trunking system was firstly introduced by Square D in 1961 in its production facility in Oxford, Ohio U.S.A. As one of the major brands of the Schneider Electric, Square D has acquired worldwide recognition in a variety of busway applications.



Square D facility in Oxford, Ohio U.S.A. is an ISO 9001 and ISO 14001 registered busbar trunking manufacturing facility.

Schneider Busway Guangzhou was initially set up by Square D, USA in 1997, and now is a professional busbar trunking manufacturer, product including I-LINE II and Canalis series, mainly supplying to the Asia Pacific and Middle East market.



Schneider Busway (Guangzhou) Ltd. is certified having ISO 9001 quality management system, ISO 14001 environment management system and OHSAS 18001 occupational health and safety management system.

Schneider busway distribution system

Distribution systems

Schneider Electric offers different distribution systems to fit your operating needs.

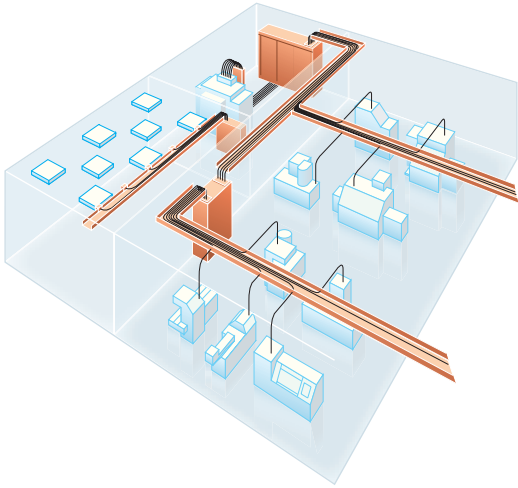

Centralised distribution

- For all continuous processes:
 - cement plants,
 - oil and gas,
 - petrochemicals,
 - steel,
 - paper, etc.
- Centralised distribution offers:
 - continuity of service,
 - combined distribution of power, control and monitoring circuits,
 - supervision, etc.

Our solutions:

- Prisma Plus and Okken switchboards.

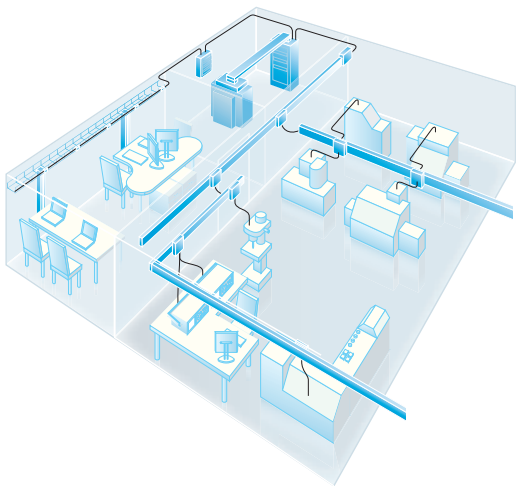

Decentralised distribution

- For manufacturing industries:
 - mechanical,
 - textiles,
 - lumber,
 - injection moulding,
 - electronics,
 - pharmaceuticals,
 - livestock, etc.
- Decentralised distribution lets you:
 - design installations without layout details,
 - upgrade without shutting down production,
 - get systems up and running sooner thanks to faster installation,
 - generate savings depending on the number of loads.

Our solutions:

- Prisma Plus switchboards,
- Schneider busbar trunking.

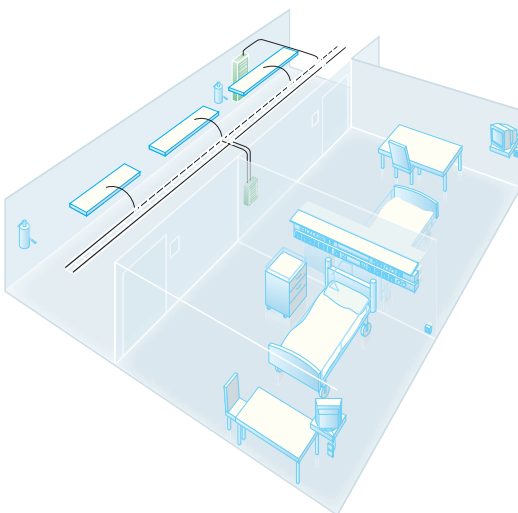

Combined distribution

Where the advantages of both centralised and decentralised distribution are required.

- Commercial and service buildings:
 - offices,
 - stores,
 - hospitals,
 - exhibition halls, etc.
- Infrastructures:
 - airports,
 - telecommunications,
 - internet data centres,
 - tunnels, etc.
- Industrial facilities:
 - pharmaceuticals,
 - food processing, etc.

Our solutions:

- Prisma Plus and Okken switchboards,
- Schneider busbar trunking.

Schneider busway distribution system

The Schneider busway decentralised distribution concept



Electrical power available at all points, throughout the installation.

Exclusive features of the Schneider Electric system

Total coordination of the Schneider Electric system provides maximum safety of life and property, continuity of service, upgradeability and ease of installation.

Product characteristics are checked by calculations and tests carried out in our laboratories and certified in independent international recognized laboratories.

A competitive installation.

Simplicity, upgradeability, safety and continuity of service and operation.

Savings start with installation

With plug-in points, Schneider busbar trunking reduces installation costs. Given the low cost of adding new circuits, savings increase as the number of loads increases, a natural consequence of the growth of your business.

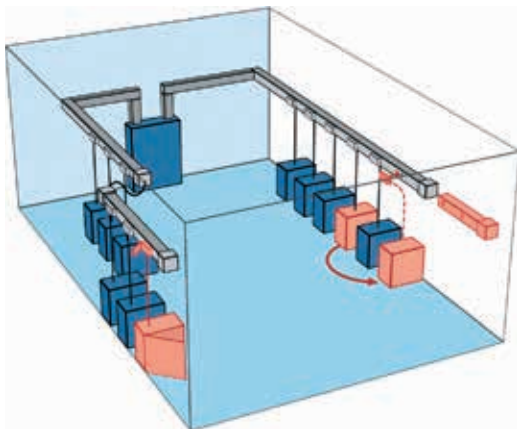
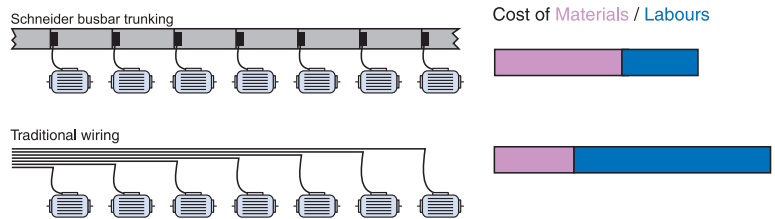

Upgradeable during operation

In decentralised distribution, evolving operating requirements and costs are integrated right from the start.

- The addition, relocation or replacement of load equipment can be carried out quickly, without de-energising the supply trunking or shutting down operation,
- The cost of making such changes is greatly reduced:
 - loads are located close to supply points,
 - plug-in points are always available,
 - plug-in units can be reused or new ones added quickly for load relocation or replacement needs.

Reusable in the event of major changes

When making major modifications to your installation, the existing trunking can be easily dismantled and reused

Schneider busway, in total harmony with the environment

Safety of life and property



Example:

Consequences of a fire in a 100 m² office with electrical distribution by cables.

200 kg of cables (i.e. 20 kg of PVC) produces:

- 4400 m³ of smoke,
- 7.5 m³ of hydrochloric acid,
- 3.7 kg of corroded steel.

With Schneider Busway, no toxic emission in case of fire

The busbar trunking has a low combustible load. Its construction uses very little consumable material and is **halogen free**.

In the event of a fire, the busbar trunking does not emit any gas or toxic smoke.

The busbar trunking helps prevent the propagation of a fire through partition walls and floors.

Halogen-sensitive applications

- Public buildings (infrastructures, hospitals, schools, etc.),
- Buildings with evacuation difficulties (high-rises, ships, etc.) and service-activity buildings,
- Sensitive processes (production of electronic components, etc.).

Schneider Busway contains no PVCs

When PVCs burn, they produce large amounts of smoke that can be a serious safety hazard.

- Reduced visibility:
 - risk of panic,
 - complicates rescue work,
- Smoke toxicity:
 - hydrogen chloride gas (highly toxic),
 - carbon monoxide (danger of asphyxiation).

Health



Schneider Busway reduces the risk of exposure to electromagnetic fields

According to the WHO (World Health Organisation), exposure to electromagnetic fields can be a health hazard starting at levels as low as 0.2 micro-Teslas and could represent a long-term risk of cancer. Some countries have created standards that stipulate limits.

All electrical conductors generate magnetic fields proportional to the distance between them. The design of Schneider busbar trunking with tightly spaced conductors in a metal enclosure helps to considerably reduce radiated electromagnetic fields. The electromagnetic field characteristics of Schneider busbar trunking are well-defined and measurements show that they are far below potentially dangerous levels.

Schneider busway, in total harmony with the environment

Environment



Example:
1 kg of PVC generates 1 kg of waste.

Schneider Busway is fully recyclable

- Schneider Busway busbar trunking can be reused. Schneider Busway busbar trunking is designed for a long service life and can easily be dismantled, cleaned and reused.
- All packaging materials can be recycled (cardboard or recyclable polyethylene film).
- All Schneider Busway products are designed for safe end-of-life recycling. PVC, on the other hand, requires neutralisation of the hydrochloric acid produced using lime and generates dioxins that are extremely toxic.

Schneider Busway helps conserve natural resources

The depletion of raw materials (copper, plastics, etc.) is one of our ongoing concerns. For this reason, we have optimised the use of all materials used to make our busbar trunking:

- Reduction of dangerous or polluting materials.
- Reduction in the weight of insulating materials.
- Reduction in the use of plastics for improving fire performance: less energy released during combustion, thereby limiting propagation and facilitating extinction (lower calorific value).

Conservation of natural resources

Schneider Busway reduces your line losses by 20%





Schneider Busway divides your consumption of plastic by a factor of four

The cost of an electrical installation includes the initial investment for the equipment and its installation, the cost of maintenance and the cost of energy losses during operation.

The concept of decentralised distribution is a way to merge all the circuits in one and thus to reduce to the maximum the low cross-section lengths and the weight of insulating materials.

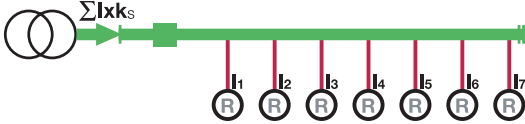
Example:

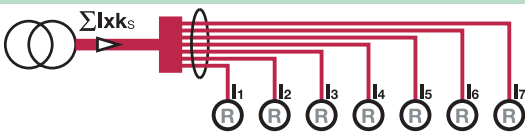
34m of 250A Schneider busbar trunking equipped with 7 sets of 25A load

Type of distribution	Insulation	Consumption
Decentralised  $\sum Ixk_s$ k_s : diversity coefficient = 0.6	 23 KG	 1600 Joules
Centralised  $\sum Ixk_s$ k_s : diversity coefficient = 0.6	 90 Kg	 2000 Joules

From the transportation to the distribution, Schneider busway is the core of your installation

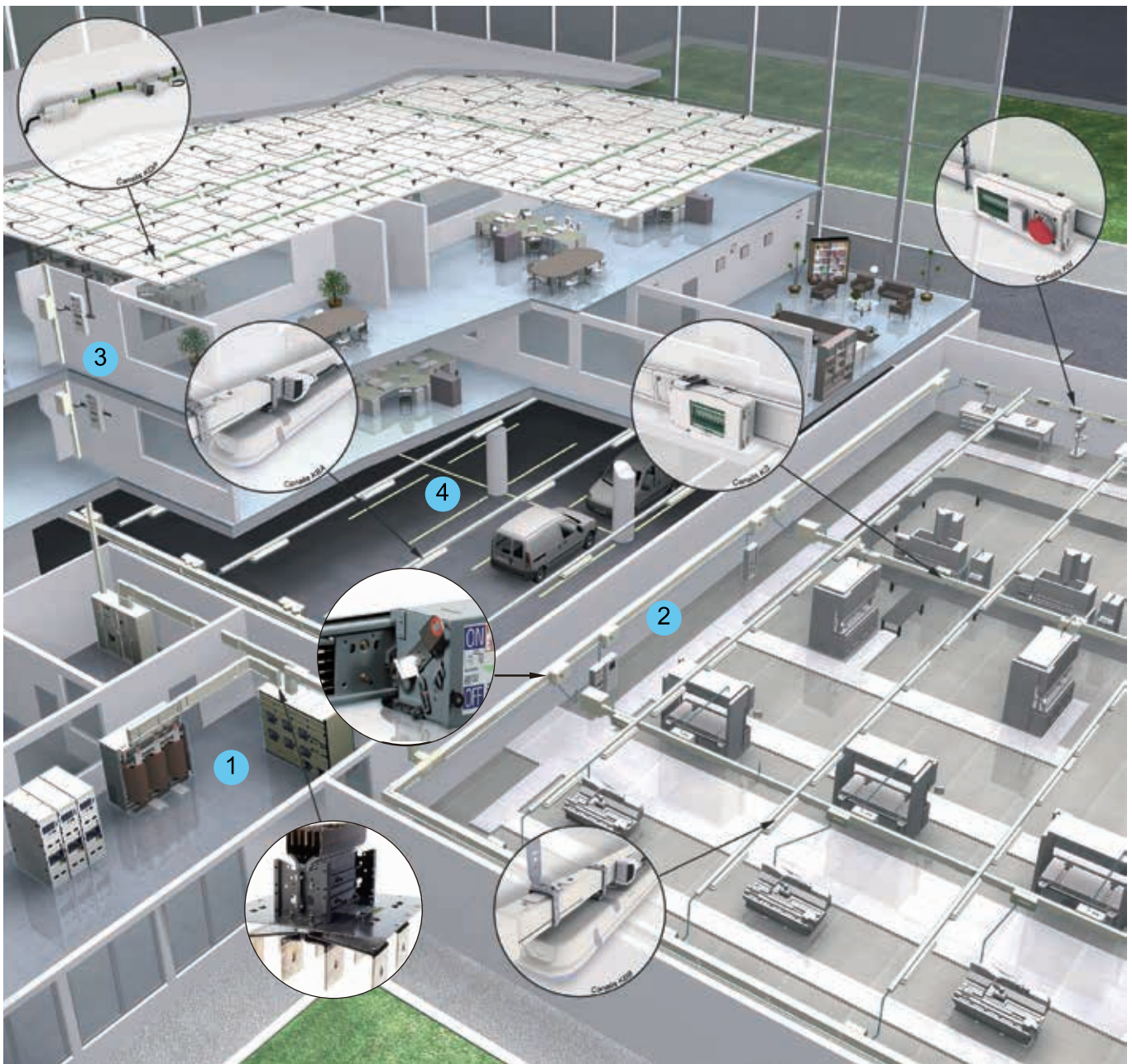

Application

1. Transformer/ Switchboard connection
2. Horizontal distribution, from the substation to the loads in workshop
3. Vertical distribution, from the substation to the loads of each high rise floor
4. Lighting application, in park place, supermarket, exhibition center, metro etc.

From the transportation to the distribution, Schneider busway is the core of your installation

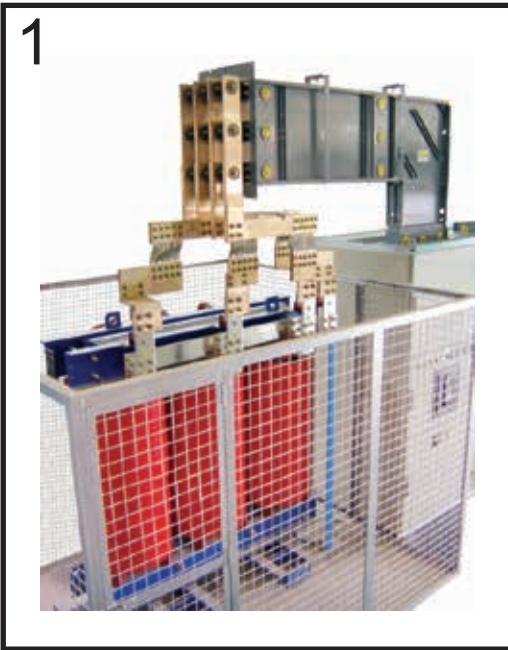

Transformer/Switchboard connection



Horizontal distribution



Vertical distribution



Lighting application

Schneider busway, a display of advantages

A compact solution

- The compact size of Schneider busway means it takes up very little space in the building:
 - used as a rising main, it takes up only a minimum of space,
 - used for horizontal distribution, it fits easily into the building's structure (false floors, false ceilings, service shafts, etc).
- Changes in direction have been designed to optimise the space taken up, contrary to an equivalent installation using cables which requires large bending radii.
- Tap-off units, completed with protective devices, are fitted along the entire length of the busbar trunking thus reducing the floor area taken up by the electrical distribution switchboards.

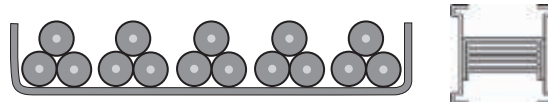

A simple and economical system

- The design study is easy to perform as it does not require a detailed layout of each load. Equipment choice is pre-determined and optimised.
- Installing the busbar trunking requires 2 or 3 people only, for a time equivalent to that for installing cableways. The time normally needed for laying cables is therefore saved.
- Connection to the MV/LV substation is made using a quick fitting joint block. The plug-in units can be prepared in the workshop thus reducing on-site time. Their connection to the busbar trunking is done in a single plugging-in operation. For those ratings more than 500A, it is done by bolt-on operation.
- Installing busbar trunking lengths can be done as and when building work progresses, thus optimising on-site work and allowing possible unexpected events to be anticipated in advance.
- It is also important to note that busbar trunking is a factory tested solution, meaning the time needed for inspecting connections is reduced (visual inspection of tightening torque).



Schneider busway, a display of advantages

Complete safety



■ Busbar trunking temperature rise and short-circuit withstand are known and independent of the installation. Coordination of the Schneider Electric system results in complete control of the electrical network.

■ Installation standards IEC 60 364 chapter 5.523.6 stipulate that **above 4 parallel cables, it is preferable to use busbar trunking**. Paralleling many cables leads to uneven distribution of currents and the risk of abnormal temperature rise.

■ The busbar trunking and plug-in units are designed to guarantee the safety of personnel and equipment

- fully silver-plated cooper contact solution.
- bolted connections with tightening torque guaranteed by torque nuts.
- foolproof system to avoid the risk of assembly errors.

Its metal enclosure and high protection degree protect the busbar trunking from all external aggressions (corrosion, rodents, etc).

Seismic Compliance



Vertical seismic test

The complete standard offer of I-Line and Canalis busway is **certified for Zone 4** seismic conditions as witness and approved by mechanical and dynamic tests, at EERTC (Earthquake Engineering Research & Test Centre) in China, as well as electrical verification test performed by CEST under IECEE CB scheme.

For projects under seismic conditions, consult your local Schneider office to provide you more information.



Horizontal seismic test

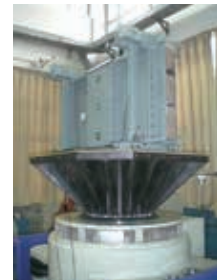

Vibration test for Marine application

Operating continuity

When working on the electrical installation, the busbar trunking provides immediate readability of the electrical circuit thus allowing the appropriate zone to be quickly identified.

The quality of the electrical contacts guarantees **maintenance free** operating continuity.

Alarge range of plug-in units



All I-LINE plug-in units are compatible with I-LINE II busbar trunking system, regardless they bear MCCB or fusible switch.

Schneider busway is adapted for all types of building

Office and Hotel buildings

Key points

- Fire barrier
- Halogen free
- Small size
- Operating continuity

Key projects

International Commerce Center (Hong Kong)
 Far Eastern U Town (Taiwan)
 Carlton Hotel (Singapore)
 Tokyo Wonderful (Japan)
 AIA 41 Exhibition Street (Australia)
 Belle Avenue (Thailand)
 Qatar Petroleum District (Qatar)
 Jabal Omar (Saudi Arabia)
 Al Othman Complex (Kuwait)
 Bitexco Financial Tower (Vietnam)
 Cipatra World (Indonesia)
 Solaire Entertainment City (Philippines)
 ...



Shopping centres and Exhibition centres

Key points

- Halogen free
- Distribution and metering
- Able to be evolved
- Sprinklers

Key projects

Carrefour Supermarket (Worldwide)
 Central Plaza Rama 9 (Thailand)
 Mall of Emirates
 Queensgate Shopping Mall (New Zealand)
 Tesco (China)
 Sahara Ganj Mall (India)
 Siam paragon (Thailand)
 Tainan Shopping Mall (Taiwan)
 World Expo (China)
 Abu Dhabi National Exhibition Center (UAE)
 Convention & Exhibition Centre (Hong Kong)
 Guangzhou International Convention & Exhibition Center (China)
 Central Market (UAE)
 ...



Schneider busway is adapted for all types of building

Industry buildings

Key points

- Operating continuity
- Able to be evolved
- Low voltage drops
- Network readability

Key projects

General Motors (World wide)
Hitachi Semiconductor Manufacturing (China)
Chartered Semiconductor Manufacturing (Singapore)
Maruti Suzuki (India)
Jabil Plant (India)
Nikon Factory (Thailand)
Intel Plant (Malaysia)
Infineon Plant (Malaysia)
Bosch (Korea)
Seagate Factory (Singapore)
ST Microelectronics (Singapore)
TSMC (Taiwan)
AUO (Taiwan)
Mitsubishi Heavy Industries Cruise Ships (Japan)
Samsung Plant (Vietnam)
Fuji Xerox (Vietnam)
...



Data centers and Banks

Key points

- Operating continuity
- High tap-off density
- Able to be evolved
- Network compactness and readability

Key projects

Bank of China Tower (Hong Kong)
Fujitsu FIP (Japan)
Dongbu Data Center (Korea)
Saudi Telecom Company (Saudi Arabia)
SM E-COM Project (Philippines)
Data Center Faasri Project (Indonesia)
IBM, Pune (India)
HP Data Center (Australia)
Hong Kong Stock Exchange (Hong Kong)
Google Yeti Data Center (Singapore)
HSBC (Hong Kong)
Credit Agricole (Egypt)
RTA Data Center (Oman)
Central Bank of Kuwait (Kuwait)
Canon West Tokyo Data Center (Japan)
Hitachi Yokohama No.3 Data Center (Japan)
...

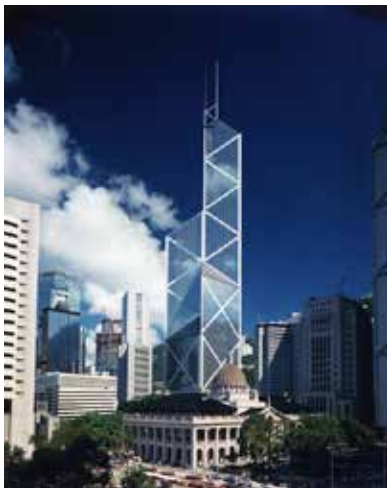

Schneider busway is adapted for all types of building

Energy

Key points

- Operating continuity
- Able to be evolved
- Low voltage drops
- Network readability

Key projects

Three Gorges Power Station (China)
Wind Farm (China)
ExxonMobil Chemical plant (Malaysia)
Hysco Steel (India)
Shell Chemical plant (Malaysia)
Petro Rabigh (Saudi Arabia)
QE II Central Energy Plant (Australia)
Assuit Aswan Gas Pipeline (Egypt)
...



Airport

Key points

- Halogen free
- Distribution and metering
- Able to be evolved
- Sprinklers

Key projects

Beijing Capital New International Airport (China)
Suvarnabhumi Airport (Thailand)
Tan Son Nhat Airport (Vietnam)
India Ahmedabad Airport (India)
Cairo Airport (Egypt)
Dubai Airport (UAE)
Jebel Ail Airport (UAE)
T2 Noi Bai Airport (Vietnam)
Muscat Airport (Oman)
...



Schneider busway is adapted for all types of building

Hospital

Key points

- Fire barrier
- Halogen free
- Small size
- Operating continuity

Key projects

The first affiliated Hospital, Guangzhou (China)
Beijing 301 Hospital (China)
Angkor International Hospital (Thailand)
Mina Hospital (Saudi Arabia)
King Abdullah Medical City (Saudi Arabia)
Arzanah Medical Complex (UAE)
Prince of Wales Hospital (Hong Kong)
Tan Tock Seng Hospital (Singapore)
National University Hospital (Singapore)
Samsung Medical Center (Korea)
Fiona Stanley Hospital (Australia)
...

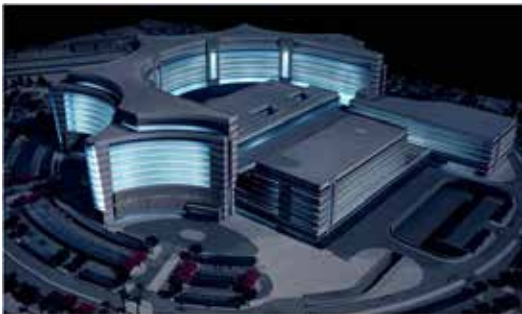

Metro

Key points

- Halogen free
- Distribution and metering
- Able to be evolved
- Sprinklers

Key projects

Guangzhou Metro (China)
Beijing Metro (China)
Dubai Metro (UAE)
Banglore Metro (India)
Delhi Metro (India)
MRT Purple Line 2 (Thailand)
Singapore Metro (Singapore)
Metro Abdibina (Indonesia)
...



Schneider busway enjoys reliable quality with complete certification

Quality- Certification



ISO9001



ISO14001



OHSAS 18001



ASEFA



DNV



ASTA Diamond



KEMA KEUR



Quality Performance



Green Leaf



UL

Safety Certification

Schneider busway performed full type test for all ratings according to IEC61439:2012 and obtained the KEMA-KEUR/ASTA Diamond certification

	KEMA KEUR / ASTA Diamond	KEMA/ASTA
Test	full type test	as specified by manufacturer
Time	continuous surveillance	one time test
Object	production line, identical to the original tested one	one sample
Standard	latest standard	as specified by manufacturer

Comprehensive 25 verifications as per latest IEC 61439-6

Comprehensive construction and performance verifications for safety and reliability

Dielectric properties

Short circuit strength

Temperature-rise limits

Resistance of insulating materials to abnormal heat and fire

Resistance to flame-propagation

Fire resistance in building penetration

Electrical characteristics

Degree of protection – dust ingress

Degree of protection – water ingress

Resistance to corrosion

Thermal Stability

Mechanical impact

Lifting Test

Structural strength

Mechanical operation

Resistance to crushing

Electrical performance

Fire Resistance

Resistance to harsh environment

Mechanical Strength

With the Schneider busway tools and services, let us compose your project

Work-out your solution together



Our teams are available to provide customers with technical assistance throughout the installation of their projects.

- Design of electrical distribution architectures:
 - design of decentralised transport and distribution systems,
 - technical and financial optimisation of busbar trunking design projects,
 - transformer / switchboard link,
 - installation coordination and discrimination.
- Full installation drawings:
 - 3D drawings with corresponding parts lists,
 - 2D drawing with dimensions,
 - detailed connection drawings.
- Site supervision and commissioning assistance.
- Training for designers and contractors.
- Missing link program.

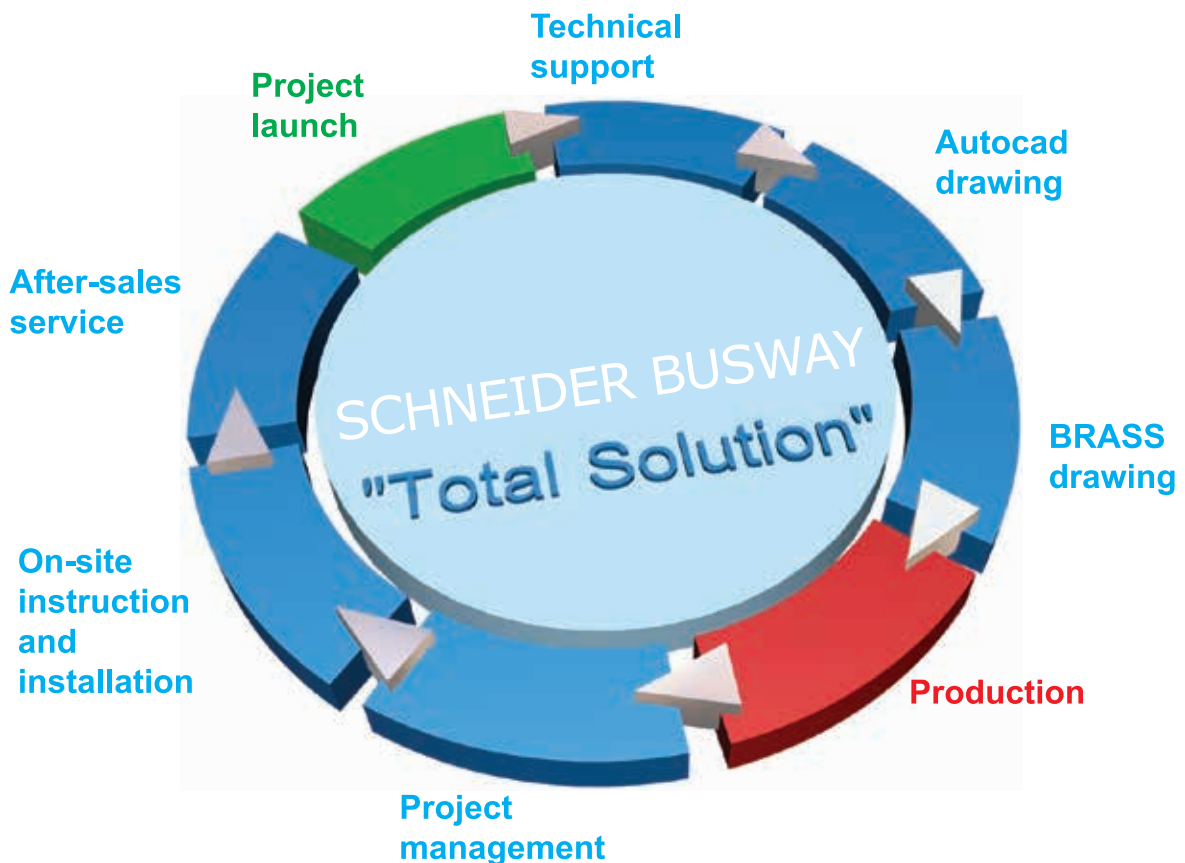

BRASS gives you all the help you need

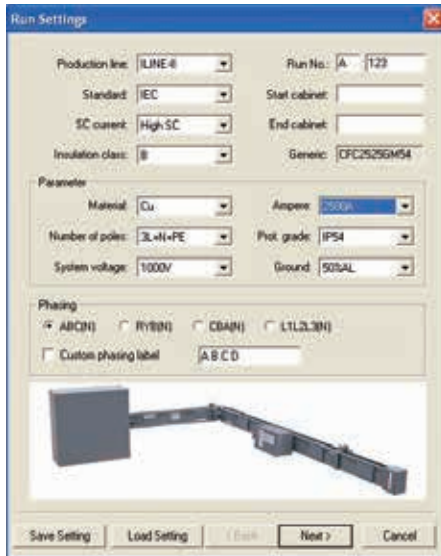

With the Schneider busway tools and services, let us compose your project!

Schneider Electric offers a comprehensive design software.

The **BRASS** software, edited by Schneider Electric, was developed to help you design I-LINE II busbar trunking runs.

BRASS, a comprehensive tool

The BRASS software allows you to quickly design the best layout for your project.

It allows:

- The material needed to be easily chosen
- A list of catalogue numbers and their exact quantities to be defined

State-of-the-art software

The advanced BRASS design software enables you design from the routing to component detail in a more accurate, convenient and quicker way.

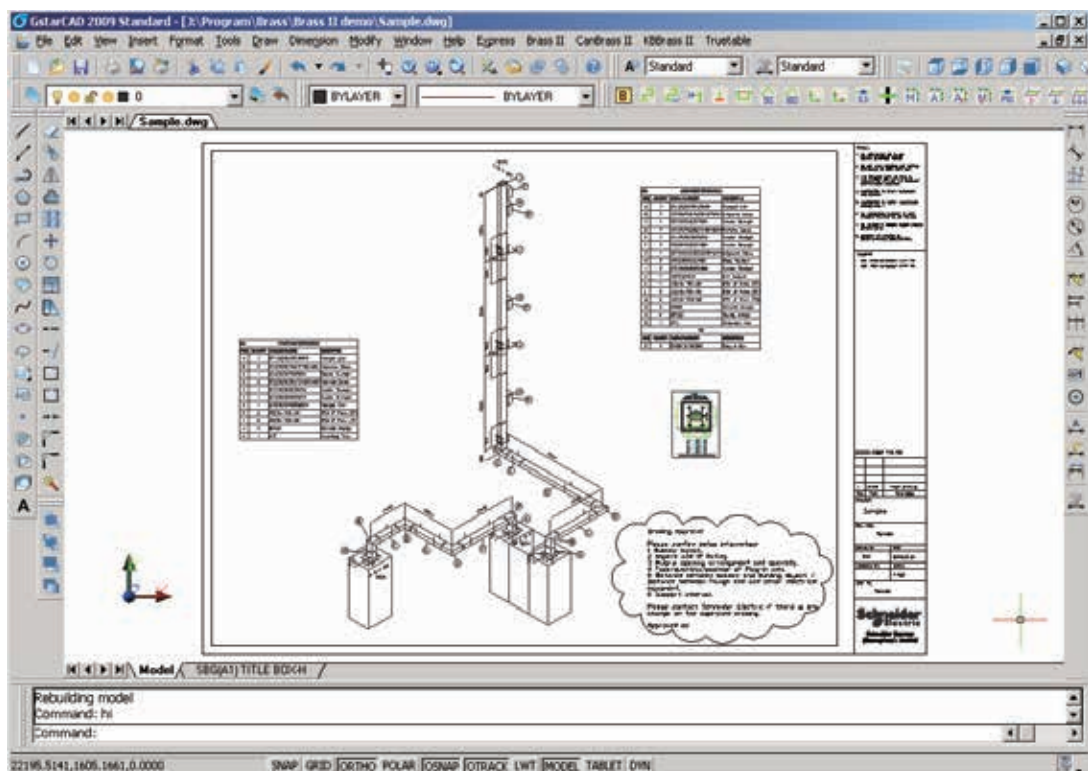

Presentation and Description

Presentation	20
Panorama of Schneider Busway Range	20
Lighting distribution	20
Power distribution	22
I-LINE II from 630 to 6300 A	24
Description	26
General	26
Straight length	28
Fitting	29
Supports and Fixings	31
Special Fitting	32
Plug-in Unit	33

Canalis

Range

Canalis KBA



Run components

Degree of protection	IP55
Number of circuits	1
Rating	25 and 40 A
Tap-off intervals	500 - 1000 and 1500 mm
Standard lengths	2 and 3 meters
Finish	Galvanised steel
Maximum distance between fixing points	3 meters

KDP-KBA-KBB tap-off units



Rating

10 and 16 A

Canalis

Canalis KBB



- IP55
- 1 or 2
- 25 and 40 A
- 500 and 1000 mm
- 2 and 3 meters
- Galvanised steel
- 5 meters



10 and 16 A

Canalis

Range	Canalis KS	Canalis KS rising mains
-------	------------	-------------------------



Run components

Degree of protection	IP52/54	IP52/54
Polarity	3L + N + PE	3L + N + PE
Rating	100, 160, 250, 400, 500, 630, 800	100, 160, 250, 400, 500, 630, 800
Tap-off intervals	1000 mm on each face	500 mm
Standard lengths	3 and 5 meters	Defined by the floor pitch
Finish	Gray white	Gray white
Maximum distance between fixing points	3 meters	Defined by the floor pitch

Tap-off units



Rating	Plug-in	25 to 400 A	25 to 400 A
	Bolt-on		

I-LINE II

I-LINE II Copper busway

I-LINE II Copper contact busway



IP40 / 41 / 54 / 65 / 66

IP40 / 41 / 54 / 65 / 66

3L + N+PE / 3L+ PE;

3L + N+PE / 3L+ PE;

630 - 6300A

800 - 5000A

610mm/1220mm

610mm/1220mm

10 Feet

10 Feet

ANSI 49

ANSI 49

10Ft

10Ft



15 to 500 A

15 to 500 A

630A to 1600 A

630A to 1600 A

I-LINE II from 630 to 6300A

High Power transport and distribution

I-LINE II

Run section

- Rating: 12 ratings are available, from 630A to 6300A
- Standard length: 10 feet, 6 feet, 4 feet
- None-standard length: minimum length 406 mm



Plug-in unit

- All I-LINE plug-in units are compatible with I-LINE II busbar trunking system
- Category: plug-in unit with MCCB,
 - Plug-in unit with Schneider Electric MCCB, ampere rating from 15A to 1000A



Elbow fitting

- **Standard elbow**
 - Flatwise elbow
 - Edgewise elbow
- **Non-standard elbow:**
 - Double elbow
 - Offset elbow
 - Elbow plus flanged end
 - Elbow in special angle
 - Elbow in special length



I-LINE II from 630 to 6300A

High Power transport and distribution

I-LINE II

Connection fitting

- Supply connections allow the busbar trunking to be connected to the switchboard's busbar or to the transformer.
- Flanged end
- Qwik Flanged end
- Cable connection, transport current between cable and busbar trunking.
- End cable tap box
- Center cable tap box



Fixing supports

- Vertical support
- Fix hanger
- Spring hanger
- Horizontal support
- Flatwise hanger
- Edgewise hanger

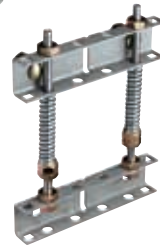

I-LINE II

The I-LINE II busbar trunking is intended for high power distribution and transport in industrial, commercial and tertiary buildings. Assembly of prefabricated sections that adapt to all run configurations.

Straight length



- 12 ratings are available, from 630A to 6300A
- Silver plated copper contact
- Insulation: DuPont Mylar polyester film, class B, 130 deg, full length insulated.
- Available polarities: 3L+PE, 3L+N+PE
- Maximum rated voltage: 1000 Volts
- Insulation voltage: 1000 Volts
- The neutral conductor has the same cross-section and capacity as the phase conductor.

Compact Size, Sandwich Structure, totally enclosed housing

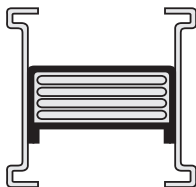

- Universal Installation, no need to consider de-rating factor, regardless of the mounting position.
 - The accumulation of dirt on exposed bus bars and possibility of accidental contact with bus bar are greatly reduced.
 - No "Chimney" effect
- Continuous air spaces inside I-line busway housing are closed off with special barriers to help prevent the spread of smoke and gases in the event of a fire in the area of the busway installation. This standard internal barrier allows busway to extend through wall or floors without creating open space for a "chimney effect" fire path.
- Improve system's ventilation, satisfy higher ampere rating
 - Less space required for installation, investment saving
 - Free of orientation
 - 7500V DC testing

The I-LINE II busbar trunking is suitable for applications containing harmonics by taking into account the appropriate derating factor. See "Harmonic currents" in the Design guide.

Joint pak



- Joint-Pak is standard on I-LINE II system. It allows for quick removal of lengths from the busbar trunking runs for load shifting or maintenance. It also can be removed and relocated on the opposite end of the length for the last minutes job changes.
- Single bolt connection makes installation faster
 - Belleville washer provides equal pressure across the complete joint contact area to assure proper electrical contact
 - Double surface contact ensure a good current continuity
 - Adjustable range: +/- 6mm



VISI - TITE Bolt

The double head design, introduced by Square D in 1967, allows the customer to tighten the joint to the proper torque using a standard spanner. The outer head will break off when the correct torque is achieved. A second bolt head remains to allow for joint maintenance or busbar relocation. No need to purchase a replacement bolt. For maintenance of the joint or when busway is relocated, the VISI-TITE bolt should be tightened to 70 lb-ft (95 Nm) with a torque wrench

Housing



- Stronger, more durable and rigid enclosure, higher mechanical strength.
- Galvanized steel, better anti-corrosion.
- Paint: Epoxy electrostatic powder finish.
- Color: ANSI 49 gray, special color are optional upon customer's request.
- Plug-in units can be loaded on either side of the busway without causing the busway to twist.
- No deformation, cracking on enclosure during transportation, handing and installation.

I-LINE II

Earthing bus

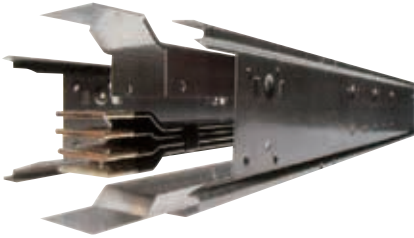

■ I-line II is furnished with the integral earthing bus as standard. The earthing bus is the bus housing itself and completely encloses the bus sandwich. It is rated at 50% capacity. The earthing bus is continuous bonding between top and bottom bus.

■ Internal Aluminum/copper earthing bus is optional.

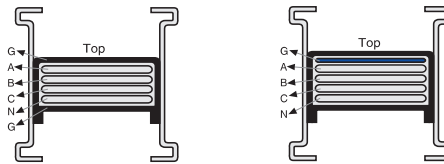

Schneider believes an earthing conductor is extremely important, to provide the maximum amount of protection for a distribution system in today's ever expanding electrical systems. With our design, we have given the maximum amount of protection in an economical package.

Conductor



Copper (Copper busway)

- 99.97% purity of copper
- Silver plated copper in full length
- minimize surface oxygenation, assure low surface contact resistance and low voltage drop
- Large cross section ensures low heat rise and voltage drop
- The effective cross sectional area of full length remains the same



Aluminum with copper contact (Copper Contact busway)

- Use silver-plated Bi-metal cladding on Aluminum conductor through high current and high pressure.
- Special process enabling molecular fusion of Copper and Aluminum through the use of very high pressure and temperature.
- Incorporates the advantage of low contact resistance of copper and lightness of aluminum, brings excellent power distribution performance.
- All contact surface are silver plated copper, ensure high energy efficiency and stable power quality.

Insulation



- Two layers surrounding each busbar, 4 layers between phases.
- Class B, 130°C, Vendor certified polyester film (DuPont Mylar)
- Excellent dielectric performance
- Over 40 years of application record without failure
- Class F is optional upon request
- Halogen free, no toxic emission, safe in the event of fire

Degree of Protection

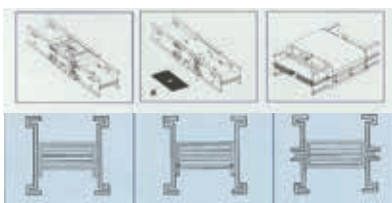

Schneider offers the I-LINE II bus bar trunking system in a variety of housing constructions to meet your application and needs.

Feeder type	IP40-IP66
Riser type	IP40-IP54
Plug-in type	IP40-IP54

Straight section

Description

Feeder

Transport the current without plug-in opening.
All straight lengths and fittings of feeder trunking are fully compatible, rating for rating, with straight lengths of plug-in trunking.

- 12 ratings are available, from 630A to 6300A
- Minimum length 406 mm
- Polarity: 3L+N+PE, 3L+PE system
- 100% neutral capacity, 50% earth bus capacity

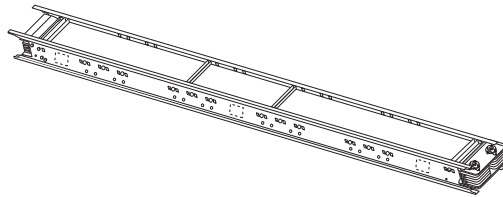

Riser

Plug-in opening (PIO) on one side, only 4, 6, 10ft available
Maximum 3 PIO for 10 feet riser element



Maximum 2 PIO for 6 feet riser element

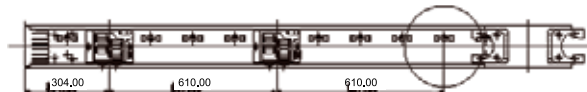

Maximum 1 PIO for 4 feet riser element

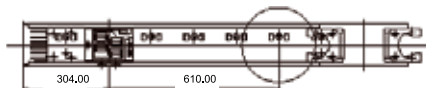

Note: tap-off outlet also can be in the circle position.

Plug-in

Plug-in opening on both sides, only 4, 6, 10ft available
Maximum 6 PIO for 10 feet plug-in element



Maximum 4 PIO for 6 feet plug-in element



Maximum 2 PIO for 4 feet plug-in element

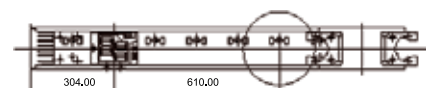

Note: tap-off outlet also can be in the circle position.

Simple change of direction

Elbow - type LF, LE and T

- to go up or down, to turn right or left
- standard angle: 90°
- special angle : 91°- 179°
- type LF, flatwise elbow

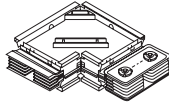

- type LE, edgewise elbow

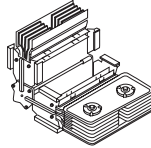

- type T, flatwise tee

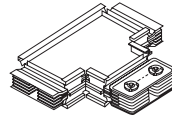

Change of direction

Double Elbow - type OF, OE, DR and DL

- flatwise or edgewise, move the run upwards, downwards, right or left direction without having to bend the busbar trunking:

- type OF, flatwise offset

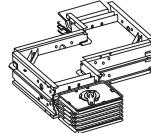

- type OE, edgewise offset

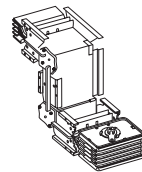

- type DR, double right elbow

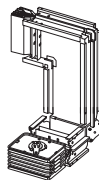

- type DL, double left elbow

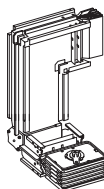

Connection to switchboard and transformer

Flanged End - type FE

They allow the busbar trunking to be connected to a switchboard's busbar, or to the terminals of an transformer, generator set, etc.

They come complete with a mounting plate fitted:

- either directly to the roof of the switchboard,
- or via the intermediary of a protective cover.

Vertical or horizontal incoming busbar trunking.

- type FE, standard flanged end

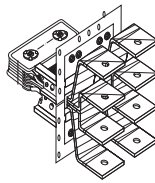

- type LEFE, edgewise elbow flanged end
- type LFFE, flatwise elbow flanged end

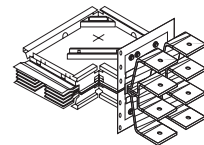
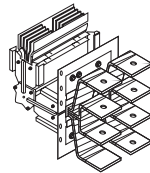

Feed Unit for Dry Type Transformer – type FET

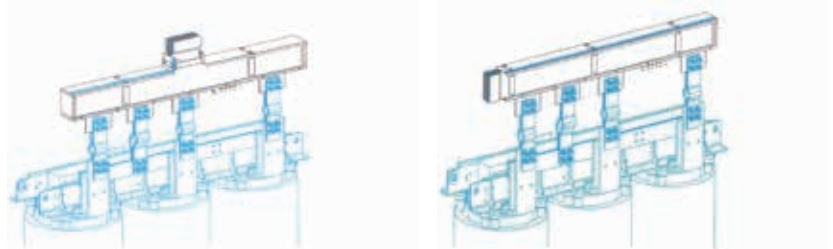

Connection to cable

Cable Tap Box

■ cable connection , transport current between cable and busbar

- type ETB, end cable tap box

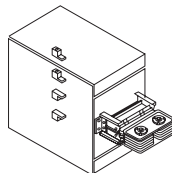

- type CTB, center cable tap box

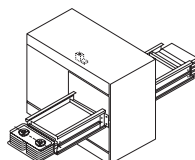

I-LINE II

Horizontal supports

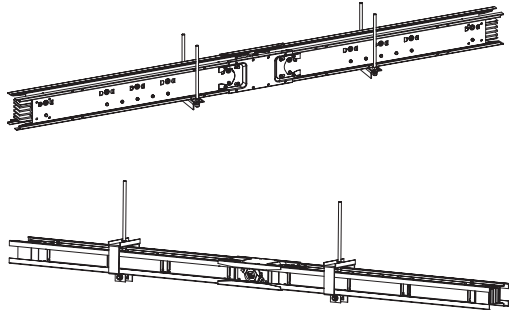

The horizontal type hanger allow the busbar trunking to be fixed and adjusted along its length, as well as absorb its movements.

- type HF●●F, flatwise hanger

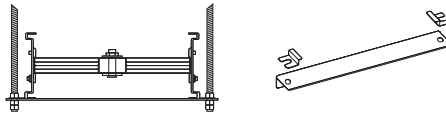

- type HF●●E, edgewise hanger

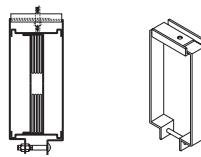

Vertical supports

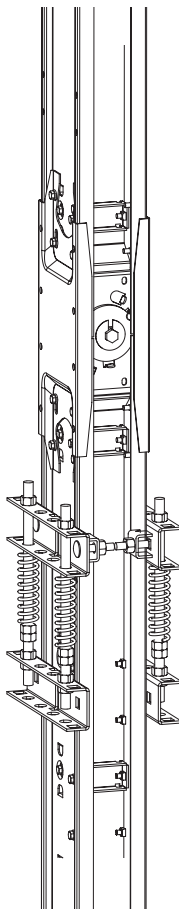

Fix Hanger

- type HFV, fix hanger, for all ratings.

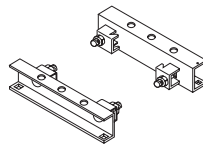

Spring Hanger

The spring hanger has the following advantages:

- spring adjustment to ensure distribution of the load at each floor
- avoids the transmission of building forces to the busbar trunking (expansion and vibration)

- type HFVS1, spring hanger

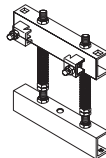

- type HFVS2, spring hanger

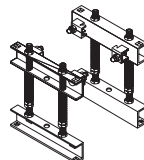

- type HFVS8, spring hanger

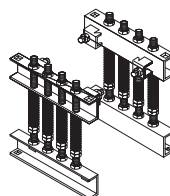

Expansion joint

- An Expansion Fitting should be used under the following conditions: whenever a busway run crosses a building expansion.
- No need for riser
- $\pm 38\text{mm}$ expansion allowable
- type EJ, absorb horizontal expansion

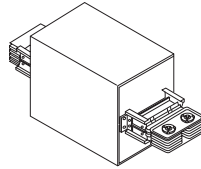

Reducer

- Connect the high power and low power run
- Best way to save investment
- Standard reducer is non-fusible, reducer with fuse/MCCB is optional
- type R

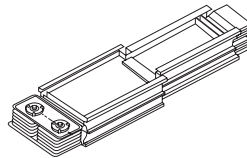

End closure

The end closure protects and insulates the conductor ends and is fitted to the last section.

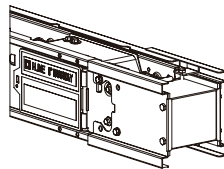

Connection accessory

Flexible link

For the connection between the conducting plates, to reduce the vibration from the transformer.



Connection plates

The conductors of flanged ends are connected via connection plates to the switchboard busbars.



I-LINE II

Product features of I-LINE II plug-in unit

**Compatibility**

All plug-in units are compatible with I-LINE II busbar trunking system, regardless they bear MCCB or fusible switch.

Plug-in device mounting

Plug-in units are positioned along the busbar trunking length by notches in the busbar trunking housing top which accept the mounting hooks of the plug-in unit. This aligns the plug-in unit jaws with the plug-in opening. After the unit is positioned on the busway, it is allowed to swing down into the plug-in opening where the plug-in jaws connect to the busbars.

Spring jaw design

- The spring jaw is composed of different metal – copper and steel.
- The spring design ensures the plug-in jaw always has firm and tight contact with the busbar regardless of hundreds of times of operation and temperature fluctuation.

Earthing

- Earthing establishes at first and switches off at last as to protect worker against electrical contact shock.
- All plug-in devices incorporate an earthing spring which cuts through the paint and forms an equipment earth between the housing and the body of the device before the phase jaws connect to the busbars.

Triple interlock

- Plug-in unit can not be switched ON until it is installed in the right position.
- When the unit is switched ON, the door can not be opened or removed from the busway.
- When the door is open, the unit can not be switched ON.

Operating handle

- The side operating handle in the PIU makes the heavy duty switch more convenient and safer.
- When the PIU is installed in the high position, you can easily operate the PIU on the group by the side handle.

Safe protection

- All plug-in units equip with Schneider original circuit breaker only, fully compatible with busway system.
- Schneider circuit breaker can provide complete overload, short circuit and earthing malfunction protection.
- Transparent shield inside the PIU can prevent a direct contact with live part.

Accurate measurement and easy communication

- Schneider plug-in unit can measure and display all kinds of electrical data accurately.
- With communication module, the date of plug-in unit can be accessed through network, making power management easier for you.

Category of I-LINE plug-in unit

Plug-in Unit with Schneider Electric MCCB



■ Plug-in Unit with Schneider Electric MCCB

- Plug-in type – PNS (15-250A), PBNS (350-500A)
- Bolt-on type PTNS (630-1000A) (different for horizontal/vertical mounting)
- Fitted with Compact NSX/ NS/ CVS(on request)
- Available for 3 pole and 4 pole configurations
- Available for earth leakage current protection (Vigi)
- IP rating up to IP54
- Operation type: side handle type or rotary type

Catalogue Numbers and Dimensions

Catalogue Number Coding	36
I-LINE II Copper Busway	
Straight Length	38
Straight Length Components	39
Elbow	41
Flanged End	51
Cable Tap Box	53
Feed Unit for Dry Type Transformer	54
Supports and Fixings	56
I-LINE II Copper Contact Busway	
Straight Length	59
Straight Length Components	60
Elbow	62
Flanged End	67
Cable Tap Box	69
Feed Unit for Dry Type Transformer	70
Supports and Fixings	72
Plug-in Unit	74

I-LINE II Copper Busway

Catalogue-number composition (I-LINE II Copper Busway)

C • D2 • • • GFEM • •

Busbar material	Code
Copper	C
Type	Code
Feeder	F
Riser	R
Plug-in	P
Standard	Code
IEC	D
I-LINE II	2
Polarity	Code
3L+PE	3
3L+N+PE(integral earth)	5
3L+N+PE(internal earth)	6
Rating	Code
630	06
800	08
1000	10
1250	12
1350	13
1600	16
2000	20
2500	25
3200	32
4000	40
5000	50
6300	63
Type of PE	Code
integral earth	G
Internal earth	GG
Type	Code
Generic Code	
Straight Length	--
Elbow	EL
Flange End	FE
Expansion Joint	EJ
End Tap Box	ETB
Center Tap Box	CTB
Flat Tee	T
Unfused Reducer	R
Discrete Code	
Edgewise Elbow	LE
Flatwise Elbow	LF
Edgewise Offset Elbow	OE
Flatwise Offset Elbow	OF
Double Left Elbow	DL
Double Right Elbow	DR
Flange End Edgewise Elbow	LEFE
Flange End Flatwise Elbow	LF FE
Flange End - Double	FEDL
Flange End - Double	FEDR
Straight Length - Feeder/Plug-in/Riser	ST
Phase Transition	PT
Degree of protection	Code
IP54	54
IP55*	55
IP65*	65

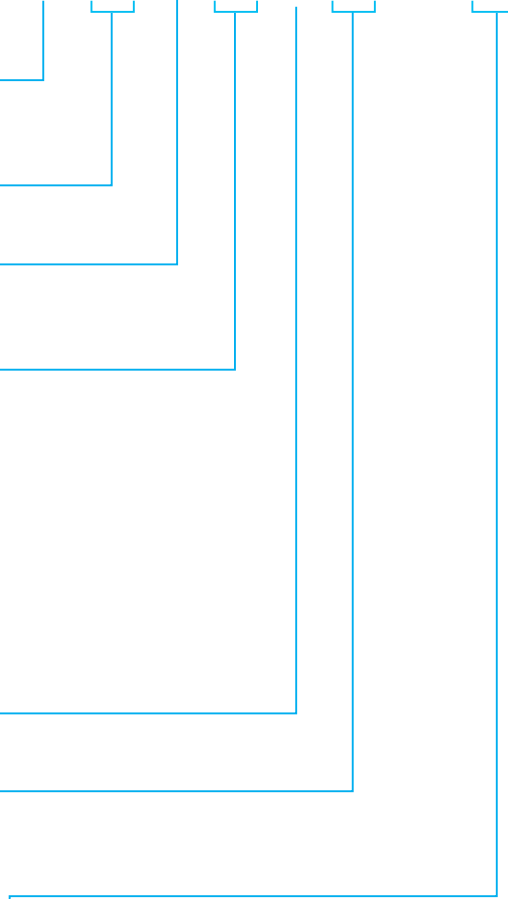

Catalogue numbers and dimensions

Catalogue Numbering System – Generic v Discrete

Generic catalogue # describes all the features of busway (e.g. copper, ampere rating, IP rating, 3/4 poles etc except length. Hence it is not for describing individual pieces of busway but rather for quotation/contract/invoicing purposes. The unit is 1 piece (for fittings) or 1 feet (straights)

Discrete catalogue # describes all the features of busway including length of the individual pieces. With the discrete catalogue number itself, it tells the detailed length of busway and is sufficient enough for production purposes. We also call this as BOM (Bill of Materials)

Generic	↔	Discrete
Example 1 CFD2508G Qty = 10 feet	↔	CFD2508G10ST Qty = 1
Example 2 CFD2508GEL Qty = 1 piece + CFD2508G Qty = 1.83 feet	↔	CFD2508GLFM11 Qty = 1

* Available for feeder system only

I-LINE II Copper Contact Busway

Catalogue-number composition (I-LINE II Copper Contact Busway)

Busbar material	Code	B ● C2 ● ● GFEM ● ● N
Bimetal	B	
Type	Code	●
Feeder	F	
Riser	R	
Plug-in	P	●
Standard	Code	
IEC	D	
I-LINE II	2	
Polarity	Code	●
3L+PE	3	
3L+N+PE(integral earth)	5	
3L+N+PE(internal earth)	6	
Rating	Code	●
800	08	
1000	10	
1250	12	
1350	13	
1600	16	
2000	20	
2500	25	
3200	32	
4000	40	
5000	50	
Type of PE	Code	●
Integral Earth	G	
Internal Earth	GG	
Type	Code	●
Generic Code		
Straight Length	--	
Elbow	EL	
Flange End	FE	
Expansion Joint	EJ	
End Tap Box	ETB	
Center Tap Box	CTB	
Flat Tee	T	
Unfused Reducer	R	
Discrete Code		
Edgewise Elbow	LE	
Flatwise Elbow	LF	
Edgewise Offset Elbow	OE	
Flatwise Offset Elbow	OF	
Double Left Elbow	DL	
Double Right Elbow	DR	
Flange End Edgewise Elbow	LEFE	
Flange End Flatwise Elbow	LFEE	
Flange End - Double	FEDL	
Flange End - Double	FEDR	
Straight Length - Feeder/Plug-in/Riser	ST	
Phase Transition	PT	
Degree of protection	Code	
IP41	41	
IP54	54	
IP55*	55	
IP65*	65	
IP66*	66	
	Code	
Milling	--	
No-milling	N	

Catalogue Numbering System – Generic v Discrete

Generic	EQV	Discrete
Example 1 BFC2508G Qty = 10 feet	↔	BFC2508G10ST Qty = 1
Example 2 BFC2508GEL Qty = 1 piece	↔	BFC2508GLFM11 Qty = 1
BFC2508G + Qty = 1.83 feet		

* Available for feeder system only

Catalogue numbers and dimensions

Ordering

Complete the catalogue number by replacing "●●" by the rating and protection degree.

Example:

Generic catalogue number of 1000A straight feeder, 3L+N+PE :



Discrete catalogue number of a 10feet 1000A straight feeder, 3L+N+PE.



**= the length of the straight feeder. If the number is larger than 10, the unit is inch. otherwise, the unit is feet.

Straight feeder length

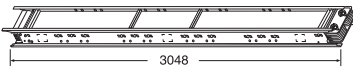

(1) See the "Trunking cross-section" table below.

Type	Length	Cat. no.		
		3L + PE	3L + N + PE(integral)	3L + N + PE(internal)
Fixed	10 Feet	CFD23●●G10STM●●	CFD25●●G10STM●●	CFD26●●GG10STM●●
Made to measure	16 inches ~ 119 inches	CFD23●●G **STM●●	CFD25●●G **STM●●	CFD26**GG **STM●●

Straight length with plug-in openings



* 10FT maximum 3 positions



* 6FT maximum 2 positions



* 4FT maximum 1 position

Type	Length	Number of opening (Nos x sides)	Cat. no.		
			3L + PE	3L + N + PE(integral)	3L + N + PE(internal)
Plug-in	4 feet	1x2	CPD23●●G4S2P00●●M●●	CPD25●●G4S2P00●●M●●	CPD26●●GG4S2P00●●M●●
		2x2	CPD23●●G6S2P00●●M●●	CPD25●●G6S2P00●●M●●	CPD26●●GG6S2P00●●M●●
	6 feet	1x2	CPD23●●G6S4P00●●M●●	CPD25●●G6S4P00●●M●●	CPD26●●GG6S4P00●●M●●
		2x2	CPD23●●G10S2P00●●M●●	CPD25●●G10S2P00●●M●●	CPD26●●GG10S2P00●●M●●
		2x2	CPD23●●G10S4P00●●M●●	CPD25●●G10S4P00●●M●●	CPD26●●GG10S4P00●●M●●
		3x2	CPD23●●G10S6P00●●M●●	CPD25●●G10S6P00●●M●●	CPD26●●GG10S6P00●●M●●
Riser	4 feet	1x1	CRD23●●G4S1P00●●M●●	CRD25●●G4S1P00●●M●●	CRD26●●GG4S1P00●●M●●
		2x1	CRD23●●G6S1P00●●M●●	CRD25●●G6S1P00●●M●●	CRD26●●GG6S1P00●●M●●
	6 feet	1x1	CRD23●●G6S2P00●●M●●	CRD25●●G6S2P00●●M●●	CRD26●●GG6S2P00●●M●●
		2x1	CRD23●●G10S1P00●●M●●	CRD25●●G10S1P00●●M●●	CRD26●●GG10S1P00●●M●●
		2x1	CRD23●●G10S2P00●●M●●	CRD25●●G10S2P00●●M●●	CRD26●●GG10S2P00●●M●●
		3x1	CRD23●●G10S3P00●●M●●	CRD25●●G10S3P00●●M●●	CRD26●●GG10S3P00●●M●●

Example:

CRD2510G10S2P024M54(PIO on one side total 2 PIO,position 2,4)
 CPD2510G10S6P135M54(PIO on both side, total 6 PIO,position 1,3,5)

"S" - the total quantity of plug-in openings
 "P" - the specific position of plug-in openings

Trunking cross-section

Rating(A)		630	800	1000	1250	1350	1600	2000	2500	3200	4000	5000	6300
Weight (kg/m)	3L + PE	14.5	14.5	15.5	20.5	21.5	25.0	29.2	37.7	57.6	70.3	87.9	108.9
	3L+ N + PE (integral)	16.9	16.9	17.8	24.9	27.6	31.0	38.7	52.7	71.0	87.6	108.0	134.8
	3L+ N + PE (internal)	18.5	18.5	19.4	26.9	29.8	33.6	42.0	57.4	77.0	95.6	116.9	146.7
W(mm)		98	98	98	110	120	136	161	212	323	412	599	638
Figure		A	A	A	A	A	A	A	A	B	B	C	C

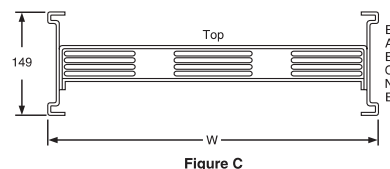
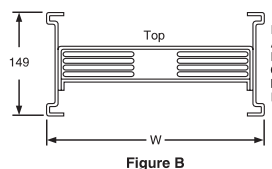
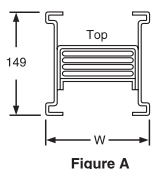

Cross Sections - Plug-In and Indoor Feeder Straight Length (IP-41 and IP-54)

Ordering

Complete the catalogue number by replacing “●●” by the rating and protection degree.

Example:

Generic catalogue number of 1000A expansion joint, 3L+N+PE :

CFD2510GEJM54

Rating Protection degree

Discrete catalogue number of a standard 1000A expansion joint, 3L+N+PE:

CFD2510GEJM54

Rating Protection degree

Expansion joint

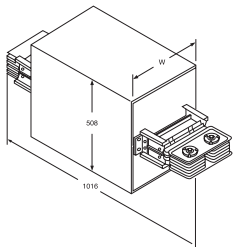

Type	Cat. no.										
	3L + PE			3L + N + PE(integral)				3L + N + PE(internal)			
Fixed	CFD23●●GEJM●●			CFD25●●GEJM●●				CFD26●●GGEJM●●			

Type	Length (mm)	Height (mm)	Width(mm)											
			630	800	1000	1250	1350	1600	2000	2500	3200	4000	5000	6300
Fixed	1016	508	343	343	343	343	343	442	442	492	594	594	819	819

Phase transition

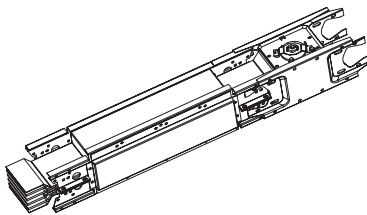

Type	Length (mm)	Cat. no.		
		3L + PE	3L + N + PE(integral)	3L + N + PE(internal)
Fixed	966	CFD23●●G38PTM●●	CFD25●●G38PTM●●	CFD26●●GG38PTM●●

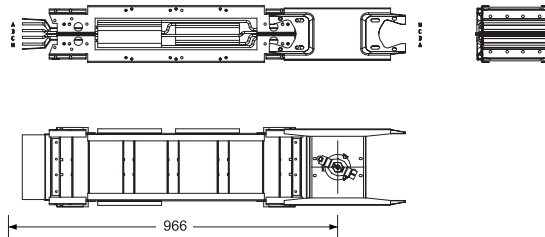

Unfused reducer

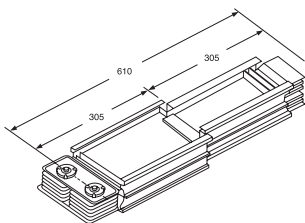

Type	Length (mm)	Cat. no.		
		3L + PE	3L + N + PE(integral)	3L + N + PE(internal)
Fixed	610	CFD23●●GR●●M●●	CFD25●●GR●●M●●	CFD26●●GGR●●M●●

Note: Replace R●● with below code. For example, CFD2520GR10M54

Bolt side											
Ampere Rating	630	800	1000	1250	1350	1600	2000	2500	3200	4000	
1250	- R06	- R08	- R10	-	-	-	-	-	-	-	-
1350	- R06	- R08	- R10	- R12	-	-	-	-	-	-	-
1600	- R06	- R08	- R10	- R12	- R13	-	-	-	-	-	-
2000	-	- R08	- R10	- R12	- R13	- R16	-	-	-	-	-
2500	-	-	- R10	- R12	- R13	- R16	- R20	-	-	-	-
3200	-	-	-	- R12	- R13	- R16	- R20	- R25	-	-	-
4000	-	-	-	-	- R13	- R16	- R20	- R25	- R32	-	-
5000	-	-	-	-	-	- R16	- R20	- R25	- R32	-	-
6300	-	-	-	-	-	-	-	- R25	- R32	- R40	-

Note: MCCB reducers are available. Contact us for details.

I-LINE II Copper Busway

End closure

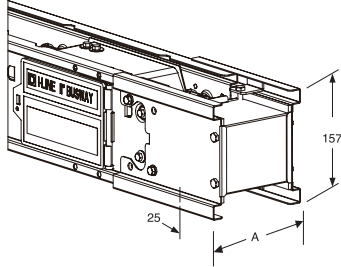

Type	Rating (A)	Dimension(mm) A	Cat. no.	
			3P	4P
End closure	630	103	ACD38EC3M●●	ACD38EC5M●●
	800	103	ACD38EC3M●●	ACD38EC5M●●
	1000	103	ACD38EC3M●●	ACD38EC5M●●
	1250	115	ACD43EC3M●●	ACD43EC5M●●
	1350	125	ACD47EC3M●●	ACD47EC5M●●
	1600	141	ACD53EC3M●●	ACD53EC5M●●
	2000	167	ACD63EC3M●●	ACD63EC5M●●
	2500	217	ACD83EC3M●●	ACD83EC5M●●
	3200	328	ACD13EC3M●●	ACD13EC5M●●
	4000	417	ACD17EC3M●●	ACD17EC5M●●
	5000	604	ACD24EC3M●●	ACD24EC5M●●
	6300	643	ACD25EC3M●●	ACD25EC5M●●

●● - Protection degree

Wall and floor flange(WF)

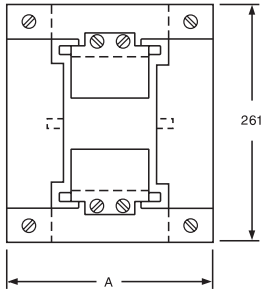

Wall and Floor Flange

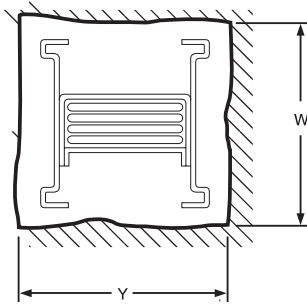

Required Wall and Floor Openings

Rating (A)	Straight Length			Flanged End		Cat. no.
	A(mm)	Y	W	Y	W	
630	211	152	203	254	381	ACF38WF
800	211	152	203	254	381	ACF38WF
1000	211	152	203	254	381	ACF38WF
1250	224	152	203	254	381	ACF43WF
1350	233	162	203	279	381	ACF47WF
1600	249	178	203	279	381	ACF53WF
2000	275	203	203	330	381	ACF63WF
2500	326	279	203	483	533	ACF83WF
3200	437	381	203	483	533	ACF13WF
4000	526	457	203	584	533	ACF17WF
5000	713	660	203	813	533	ACF24WF
6300	751	686	203	813	533	ACF25WF

Rating (A)	Flatwise Elbow Wall thickness(mm)						
	W	100	200	300	400	500	600
		Y					
630	203	229	279	330	381	432	483
800	203	229	279	330	381	432	483
1000	203	229	279	330	381	432	483
1250	203	254	305	356	407	458	509
1350	203	254	305	356	407	458	509
1600	203	305	356	407	458	509	560
2000	203	330	381	432	483	534	585
2500	203	431	482	533	584	635	686
3200	203	559	610	661	712	763	814
4000	203	686	737	788	839	890	941
5000	203	940	991	1042	1093	1144	1195
6300	203	1016	1067	1118	1169	1220	1271

Rating (A)	Edgewise Elbow Wall thickness(mm)						
	W	100	200	300	400	500	600
		Y					
630	152	305	356	406	457	509	559
800	152	305	356	406	457	509	559
1000	152	305	356	406	457	509	559
1250	152	305	356	406	457	509	559
1350	162	305	356	406	457	509	559
1600	178	305	356	406	457	509	559
2000	203	305	356	406	457	509	559
2500	279	305	356	406	457	509	559
3200	381	305	356	406	457	509	559
4000	457	305	356	406	457	509	559
5000	660	305	356	406	457	509	559
6300	686	305	356	406	457	509	559

Ordering

Complete the catalogue number by replacing “●●” by the rating and protection degree.

Example:

Generic catalogue number of 1000A flatwise elbow, 3L+N+PE :

CFD2510GELM54



Discrete catalogue number of a 24 inch, 1000A flatwise elbow, 3L+N+PE:

CFD2510G24LFS13B11M54



S - the elbow side without joint pak
B - the elbow side with joint pak

●● - the length of the elbow side with joint pak
● - the length of the elbow side without joint pak
●● - the total length of elbow

Flatwise elbow

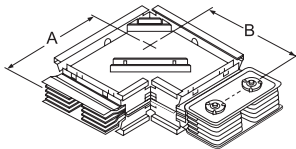

Type	Rating (A)	Cat. no.	
		3L + PE	3L + N + PE(integral)
Standard	630	CFD2306G22LFS11B11M●●	CFD2506G22LFS11B11M●●
	800	CFD2308G22LFS11B11M●●	CFD2508G22LFS11B11M●●
	1000	CFD2310G22LFS11B11M●●	CFD2510G22LFS11B11M●●
	1250	CFD2312G22LFS11B11M●●	CFD2512G22LFS11B11M●●
	1350	CFD2313G22LFS11B11M●●	CFD2513G22LFS11B11M●●
	1600	CFD2316G24LFS12B12M●●	CFD2516G24LFS12B12M●●
	2000	CFD2320G24LFS12B12M●●	CFD2520G24LFS12B12M●●
	2500	CFD2325G26LFS13B13M●●	CFD2525G26LFS13B13M●●
	3200	CFD2332G30LFS15B15M●●	CFD2532G30LFS15B15M●●
	4000	CFD2340G34LFS17B17M●●	CFD2540G34LFS17B17M●●
	5000	CFD2350G42LFS21B21M●●	CFD2550G42LFS21B21M●●
	6300	CFD2363G42LFS21B21M●●	CFD2563G42LFS21B21M●●
Made to measure	All	CFD23●●G●●LFS●●B●●M●●	CFD25●●G●●LFS●●B●●M●●

Dimension

Type	Rating (A)	Dimension (mm)	
		A	B
Standard (min)	630	279	279
	800	279	279
	1000	279	279
	1250	279	279
	1350	279	279
	1600	305	305
	2000	305	305
	2500	330	330
	3200	381	381
	4000	432	432
	5000	533	533
	6300	533	533
Made to measure	All	min ~ 1219	min ~ 1219

Flatwise elbow with made to measure angle

Type	Rating	Angle W	Cat. no.	
			3L + PE	3L + N + PE(integral)
Made to measure	All	91 ~ 179	CFD23●●G●●LFOAS●●B●●A●●M●●	CFD25●●G●●LFOAS●●B●●A●●M●●

●●=●+●, A●●=A+angle

Example - CFD2532G30LFOAS15B15A135M54

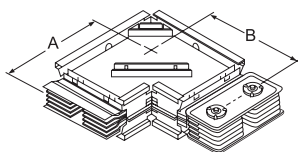

I-LINE II Copper Busway

Edgewise elbow

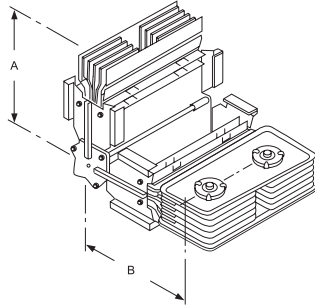

Type	Rating (A)	Cat. no	
		3L + PE	3L + N + PE(integral)
Standard	630	CFD2306G22LES11B11M●●	CFD2506G22LES11B11M●●
	800	CFD2308G22LES11B11M●●	CFD2508G22LES11B11M●●
	1000	CFD2310G22LES11B11M●●	CFD2510G22LES11B11M●●
	1250	CFD2312G22LES11B11M●●	CFD2512G22LES11B11M●●
	1350	CFD2313G22LES11B11M●●	CFD2513G22LES11B11M●●
	1600	CFD2316G22LES11B11M●●	CFD2516G22LES11B11M●●
	2000	CFD2320G22LES11B11M●●	CFD2520G22LES11B11M●●
	2500	CFD2325G22LES11B11M●●	CFD2525G22LES11B11M●●
	3200	CFD2332G22LES11B11M●●	CFD2532G22LES11B11M●●
	4000	CFD2340G22LES11B11M●●	CFD2540G22LES11B11M●●
	5000	CFD2350G22LES11B11M●●	CFD2550G22LES11B11M●●
	6300	CFD2363G22LES11B11M●●	CFD2563G22LES11B11M●●
	Made to measure	All	CFD23●●G●●LES●●B●●M●●

●●=●+●+●

Dimension

Type	Rating (A)	Dimensions(mm)	
		A	B
Standard (min)	All	279	279
Made to measure	All	min ~ 1219	min ~ 1219

Edgewise elbow with made to measure angle

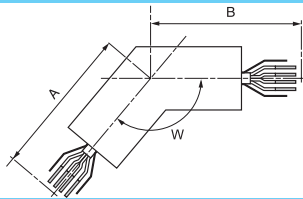

Type	Rating (A)	Angle W	Cat. no	
			3L + PE	3L + N + PE(integral)
Made to measure	All	91 ~ 179	CFD23●●G●●LEOAS●●B●●A●●M●●	CFD25●●G●●LEOAS●●B●●A●●M●●

●●=●+●+●, A●●=A+angle

Flatwise tee

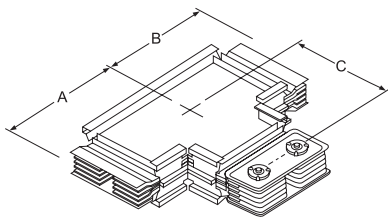

Type	Rating (A)	Cat. no	
		3L + PE	3L + N + PE(integral)
Standard	630	CFD2306G33TFS11B11S11M●●	CFD2506G33TFS11B11S11M●●
	800	CFD2308G33TFS11B11S11M●●	CFD2508G33TFS11B11S11M●●
	1000	CFD2310G33TFS11B11S11M●●	CFD2510G33TFS11B11S11M●●
	1250	CFD2312G33TFS11B11S11M●●	CFD2512G33TFS11B11S11M●●
	1350	CFD2313G33TFS11B11S11M●●	CFD2513G33TFS11B11S11M●●
	1600	CFD2316G36TFS12B12S12M●●	CFD2516G36TFS12B12S12M●●
	2000	CFD2320G36TFS12B12S12M●●	CFD2520G36TFS12B12S12M●●
	2500	CFD2325G39TFS13B13S13M●●	CFD2525G39TFS13B13S13M●●
	3200	CFD2332G45TFS15B15S15M●●	CFD2532G45TFS15B15S15M●●
	4000	CFD2340G51TFS17B17S17M●●	CFD2540G51TFS17B17S17M●●
	5000	CFD2350G63TFS21B21S21M●●	CFD2550G63TFS21B21S21M●●
	6300	CFD2363G63TFS21B21S21M●●	CFD2563G63TFS21B21S21M●●
	Made to measure	All	CFD23●●G●●TFS●●B●●S●●M●●

●●=●+●+●+●

Dimension

Type	Rating (A)	Dimension (mm)		
		A	B	C
Standard (min)	630	279	279	279
	800	279	279	279
	1000	279	279	279
	1250	279	279	279
	1350	279	279	279
	1600	305	305	305
	2000	305	305	305
	2500	330	330	330
	3200	381	381	381
	4000	432	432	432
	5000	533	533	533
6300	533	533	533	
Made to measure	All	min ~ 1219	min ~ 1219	min ~ 1219

Double Elbow

I-LINE II Copper Busway

Ordering

Complete the catalogue number by replacing “●●” by the rating and protection degree.

Example:

Generic catalogue number of 1000A double left elbow, 3L+N+PE :

CFD2510GELM54

Rating Protection degree

Discrete catalogue number of a 29 inch, 1000A double left elbow, 3L+N+PE:

CFD2510G29DLB11C07S11M54

Rating ●● ●● ●● ●● Protection degree

S - the elbow side without joint pak
 B - the elbow side with joint pak
 C or O - the straight feeder of the elbow

●● - the total length of elbow
 ●● - the length of the elbow side with joint pak
 ●● - the length of straight feeder
 ●● - the length of the elbow side without joint pak

Double left elbow

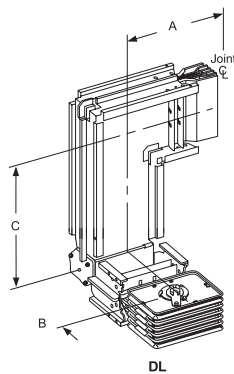

Type	Rating (A)	Cat. no	
		3L + PE	3L + N + PE(integral)
Made to measure	630	CFD2306G●●DLB●●C●●S●●M●●	CFD2506G●●DLB●●C●●S●●M●●
	800	CFD2308G●●DLB●●C●●S●●M●●	CFD2508G●●DLB●●C●●S●●M●●
	1000	CFD2310G●●DLB●●C●●S●●M●●	CFD2510G●●DLB●●C●●S●●M●●
	1250	CFD2312G●●DLB●●C●●S●●M●●	CFD2512G●●DLB●●C●●S●●M●●
	1350	CFD2313G●●DLB●●C●●S●●M●●	CFD2513G●●DLB●●C●●S●●M●●
	1600	CFD2316G●●DLB●●C●●S●●M●●	CFD2516G●●DLB●●C●●S●●M●●
	2000	CFD2320G●●DLB●●C●●S●●M●●	CFD2520G●●DLB●●C●●S●●M●●
	2500	CFD2325G●●DLB●●C●●S●●M●●	CFD2525G●●DLB●●C●●S●●M●●
	3200	CFD2332G●●DLB●●C●●S●●M●●	CFD2532G●●DLB●●C●●S●●M●●
	4000	CFD2340G●●DLB●●C●●S●●M●●	CFD2540G●●DLB●●C●●S●●M●●
	5000	CFD2350G●●DLB●●C●●S●●M●●	CFD2550G●●DLB●●C●●S●●M●●
	6300	CFD2363G●●DLB●●C●●S●●M●●	CFD2563G●●DLB●●C●●S●●M●●

Dimension

Type	Rating (A)	Dimension (mm)		
		A	B	C
Standard (min)	630	279	279	178
	800	279	279	178
	1000	279	279	178
	1250	279	279	178
	1350	279	279	178
	1600	305	279	203
	2000	305	279	203
	2500	330	279	229
	3200	381	279	279
	4000	432	279	330
	5000	533	279	457
	6300	533	279	457
	Made to measure	All	min ~ 1219	min ~ 1219

Double right elbow

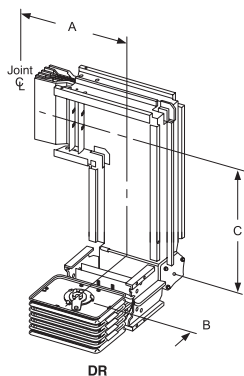

Type	Rating (A)	Cat. no	
		3L + PE	3L + N + PE(integral)
Made to measure	630	CFD2306G●●DRB●●C●●S●●M●●	CFD2506G●●DRB●●C●●S●●M●●
	800	CFD2308G●●DRB●●C●●S●●M●●	CFD2508G●●DRB●●C●●S●●M●●
	1000	CFD2310G●●DRB●●C●●S●●M●●	CFD2510G●●DRB●●C●●S●●M●●
	1250	CFD2312G●●DRB●●C●●S●●M●●	CFD2512G●●DRB●●C●●S●●M●●
	1350	CFD2313G●●DRB●●C●●S●●M●●	CFD2513G●●DRB●●C●●S●●M●●
	1600	CFD2316G●●DRB●●C●●S●●M●●	CFD2516G●●DRB●●C●●S●●M●●
	2000	CFD2320G●●DRB●●C●●S●●M●●	CFD2520G●●DRB●●C●●S●●M●●
	2500	CFD2325G●●DRB●●C●●S●●M●●	CFD2525G●●DRB●●C●●S●●M●●
	3200	CFD2332G●●DRB●●C●●S●●M●●	CFD2532G●●DRB●●C●●S●●M●●
	4000	CFD2340G●●DRB●●C●●S●●M●●	CFD2540G●●DRB●●C●●S●●M●●
	5000	CFD2350G●●DRB●●C●●S●●M●●	CFD2550G●●DRB●●C●●S●●M●●
	6300	CFD2363G●●DRB●●C●●S●●M●●	CFD2563G●●DRB●●C●●S●●M●●

Dimension

Type	Rating (A)	Dimension (mm)		
		A	B	C
Standard (min)	630	279	279	178
	800	279	279	178
	1000	279	279	178
	1250	279	279	178
	1350	279	279	178
	1600	305	279	203
	2000	305	279	203
	2500	330	279	229
	3200	381	279	279
	4000	432	279	330
	5000	533	279	457
	6300	533	279	457
	Made to measure	All	min ~ 1219	min ~ 1219

I-LINE II Copper Busway

Flatwise offset elbow

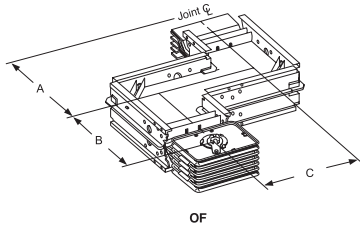

Type	Rating (A)	Cat. no	
		3L + PE	3L + N + PE(integral)
Made to measure	630	CFD2306G●●OFS●●O●●B●●M●●	CFD2506G●●OFS●●O●●B●●M●●
	800	CFD2308G●●OFS●●O●●B●●M●●	CFD2508G●●OFS●●O●●B●●M●●
	1000	CFD2310G●●OFS●●O●●B●●M●●	CFD2510G●●OFS●●O●●B●●M●●
	1250	CFD2312G●●OFS●●O●●B●●M●●	CFD2512G●●OFS●●O●●B●●M●●
	1350	CFD2313G●●OFS●●O●●B●●M●●	CFD2513G●●OFS●●O●●B●●M●●
	1600	CFD2316G●●OFS●●O●●B●●M●●	CFD2516G●●OFS●●O●●B●●M●●
	2000	CFD2320G●●OFS●●O●●B●●M●●	CFD2520G●●OFS●●O●●B●●M●●
	2500	CFD2325G●●OFS●●O●●B●●M●●	CFD2525G●●OFS●●O●●B●●M●●
	3200	CFD2332G●●OFS●●O●●B●●M●●	CFD2532G●●OFS●●O●●B●●M●●
	4000	CFD2340G●●OFS●●O●●B●●M●●	CFD2540G●●OFS●●O●●B●●M●●
	5000	CFD2350G●●OFS●●O●●B●●M●●	CFD2550G●●OFS●●O●●B●●M●●
	6300	CFD2363G●●OFS●●O●●B●●M●●	CFD2563G●●OFS●●O●●B●●M●●

●●=●●+●●+●●

Dimension

Type	Rating (A)	Dimension (mm)		
		A	B	C
Standard (min)	630	279	279	102
	800	279	279	102
	1000	279	279	102
	1250	279	279	102
	1350	279	279	102
	1600	305	305	102
	2000	305	305	152
	2500	330	330	254
	3200	381	381	356
	4000	432	432	406
	5000	533	533	584
	6300	533	533	635
	Made to measure	All	min ~ 1219	min ~ 1219

Edgewise offset elbow

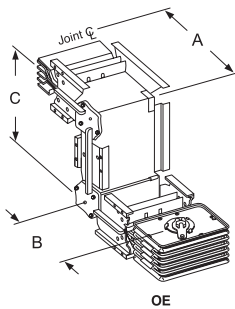

Type	Rating (A)	Cat. no	
		3L + PE	3L + N + PE(integral)
Made to measure	630	CFD2306G●●OES●●O●●B●●M●●	CFD2506G●●OES●●O●●B●●M●●
	800	CFD2308G●●OES●●O●●B●●M●●	CFD2508G●●OES●●O●●B●●M●●
	1000	CFD2310G●●OES●●O●●B●●M●●	CFD2510G●●OES●●O●●B●●M●●
	1250	CFD2312G●●OES●●O●●B●●M●●	CFD2512G●●OES●●O●●B●●M●●
	1350	CFD2313G●●OES●●O●●B●●M●●	CFD2513G●●OES●●O●●B●●M●●
	1600	CFD2316G●●OES●●O●●B●●M●●	CFD2516G●●OES●●O●●B●●M●●
	2000	CFD2320G●●OES●●O●●B●●M●●	CFD2520G●●OES●●O●●B●●M●●
	2500	CFD2325G●●OES●●O●●B●●M●●	CFD2525G●●OES●●O●●B●●M●●
	3200	CFD2332G●●OES●●O●●B●●M●●	CFD2532G●●OES●●O●●B●●M●●
	4000	CFD2340G●●OES●●O●●B●●M●●	CFD2540G●●OES●●O●●B●●M●●
	5000	CFD2350G●●OES●●O●●B●●M●●	CFD2550G●●OES●●O●●B●●M●●
	6300	CFD2363G●●OES●●O●●B●●M●●	CFD2563G●●OES●●O●●B●●M●●

●●=●●+●●+●●

Dimension

Type	Rating (A)	Dimension (mm)		
		A	B	C
Standard (min)	All	279	279	152
Made to measure	All	min ~ 1219	min ~ 1219	min ~ 1016

Flatwise elbow flanged end

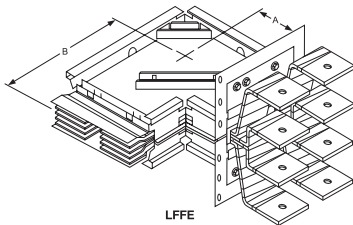

Type	Rating (A)	Cat. no	
		3L + PE	3L + N + PE(integral)
Made to measure	630	CFD2306G●●LFFE*●●F●●M●●	CFD2506G●●LFFE*●●F●●M●●
	800	CFD2308G●●LFFE*●●F●●M●●	CFD2508G●●LFFE*●●F●●M●●
	1000	CFD2310G●●LFFE*●●F●●M●●	CFD2510G●●LFFE*●●F●●M●●
	1250	CFD2312G●●LFFE*●●F●●M●●	CFD2512G●●LFFE*●●F●●M●●
	1350	CFD2313G●●LFFE*●●F●●M●●	CFD2513G●●LFFE*●●F●●M●●
	1600	CFD2316G●●LFFE*●●F●●M●●	CFD2516G●●LFFE*●●F●●M●●
	2000	CFD2320G●●LFFE*●●F●●M●●	CFD2520G●●LFFE*●●F●●M●●
	2500	CFD2325G●●LFFE*●●F●●M●●	CFD2525G●●LFFE*●●F●●M●●
	3200	CFD2332G●●LFFE*●●F●●M●●	CFD2532G●●LFFE*●●F●●M●●
	4000	CFD2340G●●LFFE*●●F●●M●●	CFD2540G●●LFFE*●●F●●M●●
	5000	CFD2350G●●LFFE*●●F●●M●●	CFD2550G●●LFFE*●●F●●M●●
	6300	CFD2363G●●LFFE*●●F●●M●●	CFD2563G●●LFFE*●●F●●M●●

●●=●●+●●

*=B or S. B - elbow side with joint pak, S - elbow side without joint pak

Type	Rating (A)	Dimension (mm)	
		A	B
Standard (min)	630	204	279
	800	204	279
	1000	204	279
	1250	204	279
	1350	204	279
	1600	204	305
	2000	229	305
	2500	254	330
	3200	305	381
	4000	356	432
	5000	457	533
	6300	457	533
	Made to measure	All	min ~ 1219

Edgewise elbow flanged end

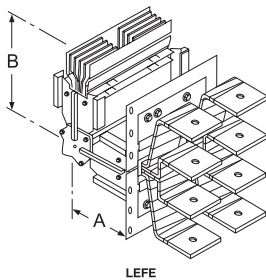

Type	Rating (A)	Cat. no	
		3L + PE	3L + N + PE(integral)
Made to measure	630	CFD2306G●●LEFE*●●F●●M●●	CFD2506G●●LEFE*●●F●●M●●
	800	CFD2308G●●LEFE*●●F●●M●●	CFD2508G●●LEFE*●●F●●M●●
	1000	CFD2310G●●LEFE*●●F●●M●●	CFD2510G●●LEFE*●●F●●M●●
	1250	CFD2312G●●LEFE*●●F●●M●●	CFD2512G●●LEFE*●●F●●M●●
	1350	CFD2313G●●LEFE*●●F●●M●●	CFD2513G●●LEFE*●●F●●M●●
	1600	CFD2316G●●LEFE*●●F●●M●●	CFD2516G●●LEFE*●●F●●M●●
	2000	CFD2320G●●LEFE*●●F●●M●●	CFD2520G●●LEFE*●●F●●M●●
	2500	CFD2325G●●LEFE*●●F●●M●●	CFD2525G●●LEFE*●●F●●M●●
	3200	CFD2332G●●LEFE*●●F●●M●●	CFD2532G●●LEFE*●●F●●M●●
	4000	CFD2340G●●LEFE*●●F●●M●●	CFD2540G●●LEFE*●●F●●M●●
	5000	CFD2350G●●LEFE*●●F●●M●●	CFD2550G●●LEFE*●●F●●M●●
	6300	CFD2363G●●LEFE*●●F●●M●●	CFD2563G●●LEFE*●●F●●M●●

●●=●●+●●

Type	Rating (A)	Dimension (mm)	
		A	B
Standard (min)	630	152	279
	800	152	279
	1000	152	279
	1250	152	279
	1350	152	279
	1600	152	279
	2000	152	279
	2500	152	279
	3200	152	279
	4000	152	279
	5000	152	279
	6300	152	279
	Made to measure	All	min ~ 1219

Catalogue numbers and dimensions

I-LINE II Copper Busway

Flatwise elbow

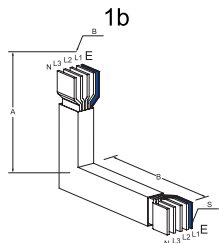
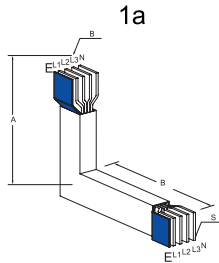

Type	Rating (A)	Cat. no	
		1a	1b
Standard	630	CFD2606GG22LFIS11B11M●●	CFD2606GG22LFOS11B11M●●
	800	CFD2608GG22LFIS11B11M●●	CFD2608GG22LFOS11B11M●●
	1000	CFD2610GG22LFIS11B11M●●	CFD2610GG22LFOS11B11M●●
	1250	CFD2612GG22LFIS11B11M●●	CFD2612GG22LFOS11B11M●●
	1350	CFD2613GG22LFIS11B11M●●	CFD2613GG22LFOS11B11M●●
	1600	CFD2616GG24LFIS12B12M●●	CFD2616GG24LFOS12B12M●●
	2000	CFD2620GG24LFIS12B12M●●	CFD2620GG24LFOS12B12M●●
	2500	CFD2625GG26LFIS13B13M●●	CFD2625GG26LFOS13B13M●●
	3200	CFD2632GG30LFIS15B15M●●	CFD2632GG30LFOS15B15M●●
	4000	CFD2640GG34LFIS17B17M●●	CFD2640GG34LFOS17B17M●●
	5000	CFD2650GG42LFIS21B21M●●	CFD2650GG42LFOS21B21M●●
	6300	CFD2663GG42LFIS21B21M●●	CFD2663GG42LFOS21B21M●●
Made to measure	All	CFD26●●GG●●LFIS●●B●●M●●	CFD26●●GG●●LFOS●●B●●M●●

●●=●●+●●

Dimension

Type	Rating (A)	Dimension (mm)	
		A	B
Standard (min)	630	279	279
	800	279	279
	1000	279	279
	1250	279	279
	1350	279	279
	1600	305	305
	2000	305	305
	2500	330	330
	3200	381	381
	4000	432	432
	5000	533	533
	6300	533	533
Made to measure	All	min ~ 1219	min ~ 1219

Flatwise elbows with made to measure angles

Type	Rating (A)	Angle (W)	3L + N + PE(integral)	
			Ground bar inside	Ground bar outside
Standard (min)	All	91 ~ 179	CFD26●●GG●●LFIOAS●●B●●A●●M●●	CFD26●●GG●●LFOOAS●●B●●A●●M●●

●●=●●+●●, A●●=A+angle

Edgewise elbow

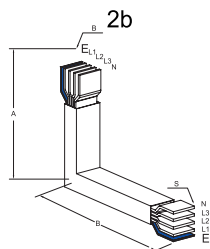
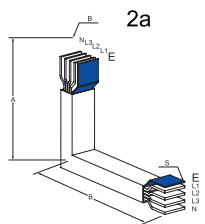

Type	Rating (A)	Cat. no	
		2a	2b
Standard	630	CFD2606GG22LEIS11B11M●●	CFD2606GG22LEOS11B11M●●
	800	CFD2608GG22LEIS11B11M●●	CFD2608GG22LEOS11B11M●●
	1000	CFD2610GG22LEIS11B11M●●	CFD2610GG22LEOS11B11M●●
	1250	CFD2612GG22LEIS11B11M●●	CFD2612GG22LEOS11B11M●●
	1350	CFD2613GG22LEIS11B11M●●	CFD2613GG22LEOS11B11M●●
	1600	CFD2616GG22LEIS11B11M●●	CFD2616GG22LEOS11B11M●●
	2000	CFD2620GG22LEIS11B11M●●	CFD2620GG22LEOS11B11M●●
	2500	CFD2625GG22LEIS11B11M●●	CFD2625GG22LEOS11B11M●●
	3200	CFD2632GG22LEIS11B11M●●	CFD2632GG22LEOS11B11M●●
	4000	CFD2640GG22LEIS11B11M●●	CFD2640GG22LEOS11B11M●●
	5000	CFD2650GG22LEIS11B11M●●	CFD2650GG22LEOS11B11M●●
	6300	CFD2663GG22LEIS11B11M●●	CFD2663GG22LEOS11B11M●●
Made to measure	All	CFD26●●GG●●LEIS●●B●●M●●	CFD26●●GG●●LEOS●●B●●M●●

●●=●●+●●

Dimension

Type	Rating (A)	Dimension (mm)	
		A	B
Standard (min)	All	279	279
Made to measure	All	min ~ 1219	min ~ 1219

I-LINE II Copper Busway

Tee-feeder

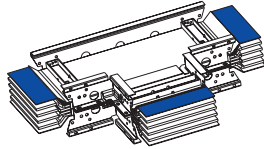

Type	Rating	Cata. no
		3L + N + PE(internal)
Standard	630	CFD2606GG33TFS11B11S11M●●
	800	CFD2608GG33TFS11B11S11M●●
	1000	CFD2610GG33TFS11B11S11M●●
	1250	CFD2612GG33TFS11B11S11M●●
	1350	CFD2613GG33TFS11B11S11M●●
	1600	CFD2616GG36TFS12B12S12M●●
	2000	CFD2620GG36TFS12B12S12M●●
	2500	CFD2625GG39TFS13B13S13M●●
	3200	CFD2632GG45TFS15B15S15M●●
	4000	CFD2640GG51TFS17B17S17M●●
	5000	CFD2650GG63TFS21B21S21M●●
	6300	CFD2663GG63TFS21B21S21M●●
	Made to measure	All

●●=●●+●●+●●

Type	Rating (A)	Dimension (mm)		
		A	B	C
Standard (min)	630	279	279	279
	800	279	279	279
	1000	279	279	279
	1250	279	279	279
	1350	279	279	279
	1600	305	305	305
	2000	305	305	305
	2500	330	330	330
	3200	381	381	381
	4000	432	432	432
	5000	533	533	533
	6300	533	533	533
	Made to measure	All	min ~ 1219	min ~ 1219

Double left elbow

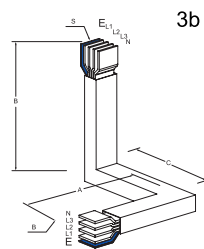
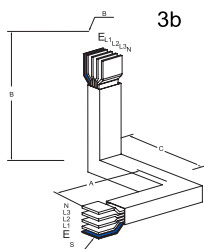
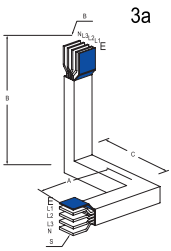
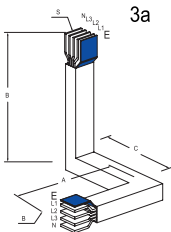

Type	Rating (A)	Cat. no	
		3a	3b
Made to measure	630	CFD2606GG●●DLIB●●C●●S●●M●●	CFD2606GG●●DLOB●●C●●S●●M●●
	800	CFD2608GG●●DLIB●●C●●S●●M●●	CFD2608GG●●DLOB●●C●●S●●M●●
	1000	CFD2610GG●●DLIB●●C●●S●●M●●	CFD2610GG●●DLOB●●C●●S●●M●●
	1250	CFD2612GG●●DLIB●●C●●S●●M●●	CFD2612GG●●DLOB●●C●●S●●M●●
	1350	CFD2613GG●●DLIB●●C●●S●●M●●	CFD2613GG●●DLOB●●C●●S●●M●●
	1600	CFD2616GG●●DLIB●●C●●S●●M●●	CFD2616GG●●DLOB●●C●●S●●M●●
	2000	CFD2620GG●●DLIB●●C●●S●●M●●	CFD2620GG●●DLOB●●C●●S●●M●●
	2500	CFD2625GG●●DLIB●●C●●S●●M●●	CFD2625GG●●DLOB●●C●●S●●M●●
	3200	CFD2632GG●●DLIB●●C●●S●●M●●	CFD2632GG●●DLOB●●C●●S●●M●●
	4000	CFD2640GG●●DLIB●●C●●S●●M●●	CFD2640GG●●DLOB●●C●●S●●M●●
	5000	CFD2650GG●●DLIB●●C●●S●●M●●	CFD2650GG●●DLOB●●C●●S●●M●●
	6300	CFD2663GG●●DLIB●●C●●S●●M●●	CFD2663GG●●DLOB●●C●●S●●M●●

●●=●●+●●+●●

Type	Rating (A)	Dimension (mm)		
		A	B	C
Standard (min)	630	279	279	178
	800	279	279	178
	1000	279	279	178
	1250	279	279	178
	1350	279	279	178
	1600	305	279	203
	2000	305	279	203
	2500	330	279	227
	3200	381	279	279
	4000	432	279	330
	5000	533	279	457
	6300	533	279	457
	Made to measure	All	min ~ 1219	min ~ 1219

Catalogue numbers and dimensions

I-LINE II Copper Busway

Double right elbow

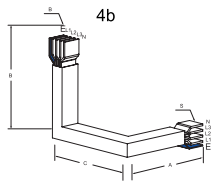
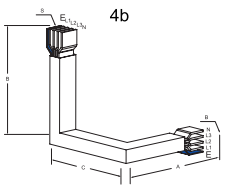
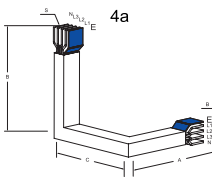
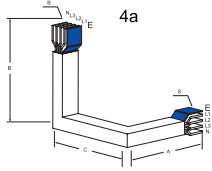

Type	Rating (A)	Cat. no	
		4a	4b
Made to measure	630	CFD2606GG●●DRIB●●C●S●●M●●	CFD2606GG●●DROB●●C●S●●M●●
	800	CFD2608GG●●DRIB●●C●S●●M●●	CFD2608GG●●DROB●●C●S●●M●●
	1000	CFD2610GG●●DRIB●●C●S●●M●●	CFD2610GG●●DROB●●C●S●●M●●
	1250	CFD2612GG●●DRIB●●C●S●●M●●	CFD2612GG●●DROB●●C●S●●M●●
	1350	CFD2613GG●●DRIB●●C●S●●M●●	CFD2613GG●●DROB●●C●S●●M●●
	1600	CFD2616GG●●DRIB●●C●S●●M●●	CFD2616GG●●DROB●●C●S●●M●●
	2000	CFD2620GG●●DRIB●●C●S●●M●●	CFD2620GG●●DROB●●C●S●●M●●
	2500	CFD2625GG●●DRIB●●C●S●●M●●	CFD2625GG●●DROB●●C●S●●M●●
	3200	CFD2632GG●●DRIB●●C●S●●M●●	CFD2632GG●●DROB●●C●S●●M●●
	4000	CFD2640GG●●DRIB●●C●S●●M●●	CFD2640GG●●DROB●●C●S●●M●●
	5000	CFD2650GG●●DRIB●●C●S●●M●●	CFD2650GG●●DROB●●C●S●●M●●
	6300	CFD2663GG●●DRIB●●C●S●●M●●	CFD2663GG●●DROB●●C●S●●M●●

●●●●●●●●●●●●●●●●

Dimension

Type	Rating (A)	Dimension (mm)		
		A	B	C
Standard (min)	630	279	279	178
	800	279	279	178
	1000	279	279	178
	1250	279	279	178
	1350	279	279	178
	1600	305	279	203
	2000	305	279	203
	2500	330	279	229
	3200	381	279	279
	4000	432	279	330
Made to measure	5000	533	279	457
	6300	533	279	457
	All	min ~ 1219	min ~ 1219	min ~ 1016

Flatwise offset elbow

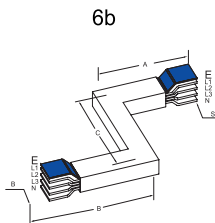
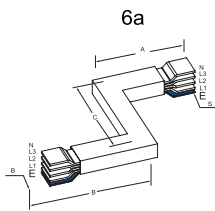

Type	Rating (A)	Cat. no	
		6a	6b
Made to measure	630	CFD2606GG●●OFIS●●O●B●●M●●	CFD2606GG●●OFOS●●O●B●●M●●
	800	CFD2608GG●●OFIS●●O●B●●M●●	CFD2608GG●●OFOS●●O●B●●M●●
	1000	CFD2610GG●●OFIS●●O●B●●M●●	CFD2610GG●●OFOS●●O●B●●M●●
	1250	CFD2612GG●●OFIS●●O●B●●M●●	CFD2612GG●●OFOS●●O●B●●M●●
	1350	CFD2613GG●●OFIS●●O●B●●M●●	CFD2613GG●●OFOS●●O●B●●M●●
	1600	CFD2616GG●●OFIS●●O●B●●M●●	CFD2616GG●●OFOS●●O●B●●M●●
	2000	CFD2620GG●●OFIS●●O●B●●M●●	CFD2620GG●●OFOS●●O●B●●M●●
	2500	CFD2625GG●●OFIS●●O●B●●M●●	CFD2625GG●●OFOS●●O●B●●M●●
	3200	CFD2632GG●●OFIS●●O●B●●M●●	CFD2632GG●●OFOS●●O●B●●M●●
	4000	CFD2640GG●●OFIS●●O●B●●M●●	CFD2640GG●●OFOS●●O●B●●M●●
	5000	CFD2650GG●●OFIS●●O●B●●M●●	CFD2650GG●●OFOS●●O●B●●M●●
	6300	CFD2663GG●●OFIS●●O●B●●M●●	CFD2663GG●●OFOS●●O●B●●M●●

●●●●●●●●●●●●●●●●

Dimension

Type	Rating (A)	Dimension (mm)		
		A	B	C
Standard (min)	630	279	279	102
	800	279	279	102
	1000	279	279	102
	1250	279	279	102
	1350	279	279	102
	1600	305	305	102
	2000	305	305	152
	2500	330	330	254
	3200	381	381	356
	4000	432	432	406
Made to measure	5000	533	533	584
	6300	533	533	635
	All	min ~ 1219	min ~ 1219	min ~ 1016

Catalogue numbers and dimensions

I-LINE II Copper Busway

Edgewise offset elbow

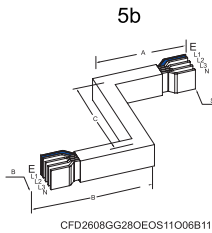
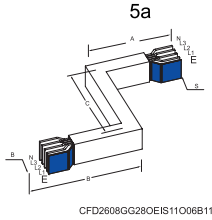

Type	Rating (A)	Cat. no	
		5a	5b
Made to measure	630	CFD2606GG●●OEIS●●●●●●●●●●	CFD2606GG●●OEOS●●●●●●●●●●
	800	CFD2608GG●●OEIS●●●●●●●●●●	CFD2608GG●●OEOS●●●●●●●●●●
	1000	CFD2610GG●●OEIS●●●●●●●●●●	CFD2610GG●●OEOS●●●●●●●●●●
	1250	CFD2612GG●●OEIS●●●●●●●●●●	CFD2612GG●●OEOS●●●●●●●●●●
	1350	CFD2613GG●●OEIS●●●●●●●●●●	CFD2613GG●●OEOS●●●●●●●●●●
	1600	CFD2616GG●●OEIS●●●●●●●●●●	CFD2616GG●●OEOS●●●●●●●●●●
	2000	CFD2620GG●●OEIS●●●●●●●●●●	CFD2620GG●●OEOS●●●●●●●●●●
	2500	CFD2625GG●●OEIS●●●●●●●●●●	CFD2625GG●●OEOS●●●●●●●●●●
	3200	CFD2632GG●●OEIS●●●●●●●●●●	CFD2632GG●●OEOS●●●●●●●●●●
	4000	CFD2640GG●●OEIS●●●●●●●●●●	CFD2640GG●●OEOS●●●●●●●●●●
	5000	CFD2650GG●●OEIS●●●●●●●●●●	CFD2650GG●●OEOS●●●●●●●●●●
	6300	CFD2663GG●●OEIS●●●●●●●●●●	CFD2663GG●●OEOS●●●●●●●●●●

●●●●●●●●●●

Type	Rating (A)	Dimension (mm)		
		A	B	C
Standard (min)	All	279	279	152
Made to measure	All	min ~ 1219	min ~ 1219	min ~ 1016

Flanged end flatwise elbow

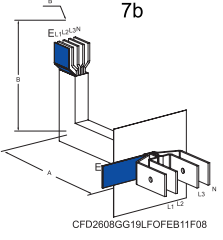
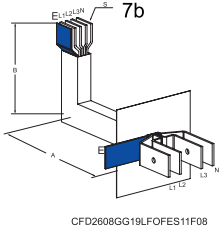
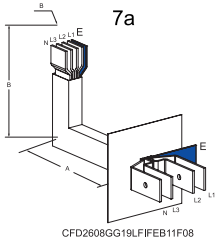
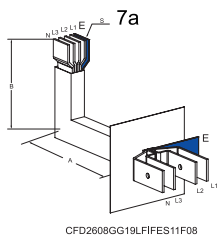

Type	Rating (A)	Cat. no	
		7a	7b
Made to measure	630	CFD2606GG●●LFIFE*●●●●●●●●●●	CFD2606GG●●LFOFE*●●●●●●●●●●
	800	CFD2608GG●●LFIFE*●●●●●●●●●●	CFD2608GG●●LFOFE*●●●●●●●●●●
	1000	CFD2610GG●●LFIFE*●●●●●●●●●●	CFD2610GG●●LFOFE*●●●●●●●●●●
	1250	CFD2612GG●●LFIFE*●●●●●●●●●●	CFD2612GG●●LFOFE*●●●●●●●●●●
	1350	CFD2613GG●●LFIFE*●●●●●●●●●●	CFD2613GG●●LFOFE*●●●●●●●●●●
	1600	CFD2616GG●●LFIFE*●●●●●●●●●●	CFD2616GG●●LFOFE*●●●●●●●●●●
	2000	CFD2620GG●●LFIFE*●●●●●●●●●●	CFD2620GG●●LFOFE*●●●●●●●●●●
	2500	CFD2625GG●●LFIFE*●●●●●●●●●●	CFD2625GG●●LFOFE*●●●●●●●●●●
	3200	CFD2632GG●●LFIFE*●●●●●●●●●●	CFD2632GG●●LFOFE*●●●●●●●●●●
	4000	CFD2640GG●●LFIFE*●●●●●●●●●●	CFD2640GG●●LFOFE*●●●●●●●●●●
	5000	CFD2650GG●●LFIFE*●●●●●●●●●●	CFD2650GG●●LFOFE*●●●●●●●●●●
	6300	CFD2663GG●●LFIFE*●●●●●●●●●●	CFD2663GG●●LFOFE*●●●●●●●●●●

●●●●●●●●●●

* = B or S. B - elbow side with joint pak, S - elbow side without joint pak

Type	Rating (A)	Dimension (mm)	
		A	B
Standard (min)	630	204	279
	800	204	279
	1000	204	279
	1250	204	279
	1350	204	279
	1600	204	305
	2000	229	305
	2500	254	330
	3200	305	381
	4000	356	432
	5000	457	533
	6300	457	533
	Made to measure	All	min ~ 1219

Catalogue numbers and dimensions

Flanged end edgewise elbow

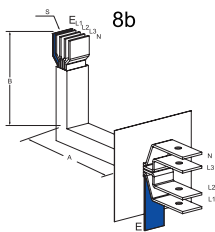
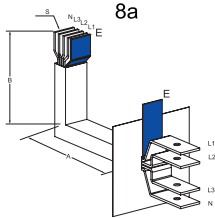

Type	Rating (A)	Cat. no	
		8a	8b
Made to measure	630	CFD2606GG●●LEIFE*●●F●●M●●	CFD2606GG●●LEOFE*●●F●●M●●
	800	CFD2608GG●●LEIFE*●●F●●M●●	CFD2608GG●●LEOFE*●●F●●M●●
	1000	CFD2610GG●●LEIFE*●●F●●M●●	CFD2610GG●●LEOFE*●●F●●M●●
	1250	CFD2612GG●●LEIFE*●●F●●M●●	CFD2612GG●●LEOFE*●●F●●M●●
	1350	CFD2613GG●●LEIFE*●●F●●M●●	CFD2613GG●●LEOFE*●●F●●M●●
	1600	CFD2616GG●●LEIFE*●●F●●M●●	CFD2616GG●●LEOFE*●●F●●M●●
	2000	CFD2620GG●●LEIFE*●●F●●M●●	CFD2620GG●●LEOFE*●●F●●M●●
	2500	CFD2626GG●●LEIFE*●●F●●M●●	CFD2626GG●●LEOFE*●●F●●M●●
	3200	CFD2632GG●●LEIFE*●●F●●M●●	CFD2632GG●●LEOFE*●●F●●M●●
	4000	CFD2640GG●●LEIFE*●●F●●M●●	CFD2640GG●●LEOFE*●●F●●M●●
	5000	CFD2650GG●●LEIFE*●●F●●M●●	CFD2650GG●●LEOFE*●●F●●M●●
	6300	CFD2663GG●●LEIFE*●●F●●M●●	CFD2663GG●●LEOFE*●●F●●M●●

●●=●●+●●

* = B or S. B - elbow side with joint pak, S - elbow side without joint pak

Dimension

Type	Rating (A)	Dimension (mm)	
		A	B
Standard (min)	All	152	279
Made to measure	All	min ~ 1219	min ~ 1219

Flanged End

Ordering

Complete the catalogue number by replacing “●●” by the rating and protection degree.

Example:

Generic catalogue number of 1000 A flanged end, 3L+N+PE:

CFD2510GFEM54

Rating Protection degree

Discrete catalogue number example of a 12 inch, 1000A flanged end, 3L+N+PE:

CFD2510G12FEBM54

Rating ●● * Protection degree

●● - the length of the straight feeder of flanged end
* = B or S. B - with joint pak, S - without joint pak

Flanged end

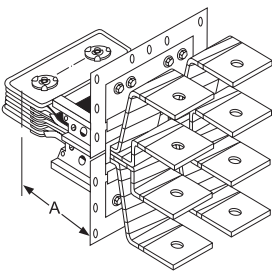

Type	Rating (A)	Cat. no		
		3L + PE	3L + N + PE(integral)	3L + N + PE(internal)
Standard	All	CFD23●●G10FE*M●●	CFD25●●G10FE*M●●	CFD26●●GG10FE*M●●
Made to measure	630	CFD2306G●●FE*M●●	CFD2506G●●FE*M●●	CFD2606GG●●FE*M●●
	800	CFD2308G●●FE*M●●	CFD2508G●●FE*M●●	CFD2608GG●●FE*M●●
	1000	CFD2310G●●FE*M●●	CFD2510G●●FE*M●●	CFD2610GG●●FE*M●●
	1250	CFD2312G●●FE*M●●	CFD2512G●●FE*M●●	CFD2612GG●●FE*M●●
	1350	CFD2313G●●FE*M●●	CFD2513G●●FE*M●●	CFD2613GG●●FE*M●●
	1600	CFD2316G●●FE*M●●	CFD2516G●●FE*M●●	CFD2616GG●●FE*M●●
	2000	CFD2320G●●FE*M●●	CFD2520G●●FE*M●●	CFD2620GG●●FE*M●●
	2500	CFD2325G●●FE*M●●	CFD2525G●●FE*M●●	CFD2625GG●●FE*M●●
	3200	CFD2332G●●FE*M●●	CFD2532G●●FE*M●●	CFD2632GG●●FE*M●●
	4000	CFD2340G●●FE*M●●	CFD2540G●●FE*M●●	CFD2640GG●●FE*M●●
	5000	CFD2350G●●FE*M●●	CFD2550G●●FE*M●●	CFD2650GG●●FE*M●●
	6300	CFD2363G●●FE*M●●	CFD2563G●●FE*M●●	CFD2663GG●●FE*M●●

Dimension

Type	Rating (A)	Dimension (mm)
Standard	All	A
Made to measure	All	254
		min ~ 1219

Rating (A)	Dimension (mm)			
	A	B	C	D
630	162	81	-	-
800	162	81	-	-
1000	162	81	-	-
1250	162	81	-	-
1350	178	89	-	-
1600	178	89	-	-
2000	229	114	-	-
2500	378	127	-	-
3200	378	127	-	-
4000	480	121	119	-
5000	705	117	118	118
6300	705	117	118	118

Flanged Collar and Cutout and Drilling Template 630A-6300A Feeder

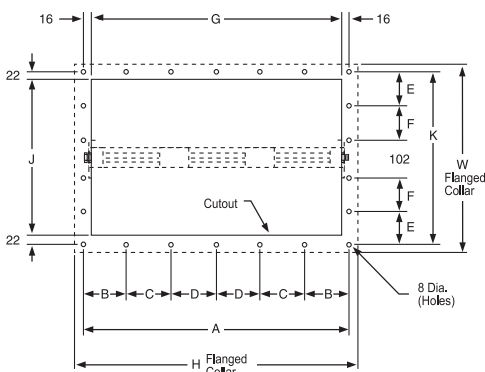

Rating (A)	N Holes	Dimension (mm)							
		E	F	G	H	J	K	W	
								3-Pole	4-Pole
630	10	98	-	130	187	254	296	326	335
800	10	98	-	130	187	254	296	326	335
1000	10	98	-	130	187	254	296	326	335
1250	10	98	-	130	187	254	296	326	335
1350	10	98	-	146	203	254	296	326	335
1600	10	98	-	146	203	254	296	326	335
2000	10	98	-	196	254	254	296	326	335
2500	16	88	87	346	403	406	451	478	487
3200	16	88	87	346	403	406	451	478	487
4000	18	88	87	448	505	406	451	478	487
5000	22	88	87	673	730	406	451	478	487
6300	22	88	87	673	730	406	451	478	487

I-LINE II Copper Busway

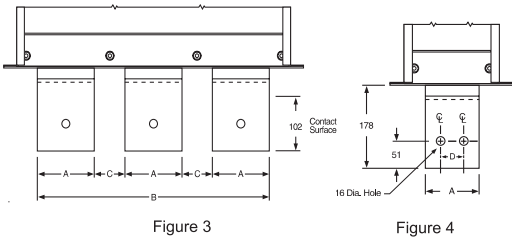
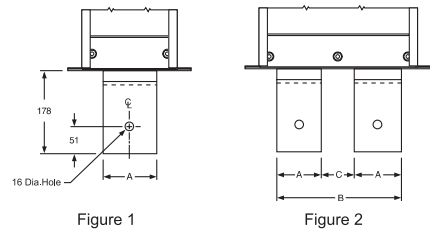
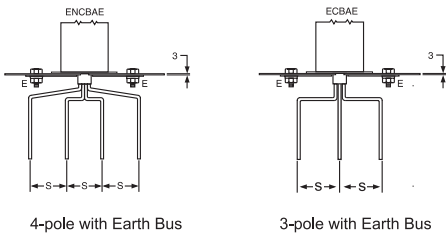
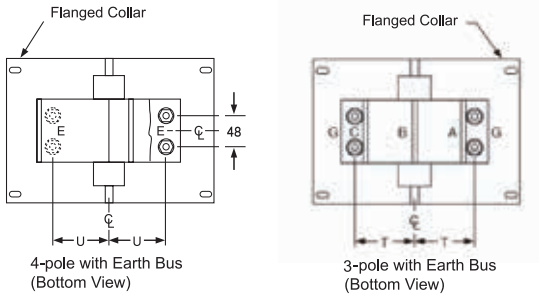

Physical Data

Rating (A)	Dimension (mm)		
	S	T	U
630	76	92	97
800	76	92	97
1000	76	92	97
1250	76	92	97
1350	76	92	97
1600	76	92	97
2000	76	92	97
2500	127	169	173
3200	127	169	173
4000	127	169	173
5000	127	169	173
6300	127	169	173

Flanged end termination details

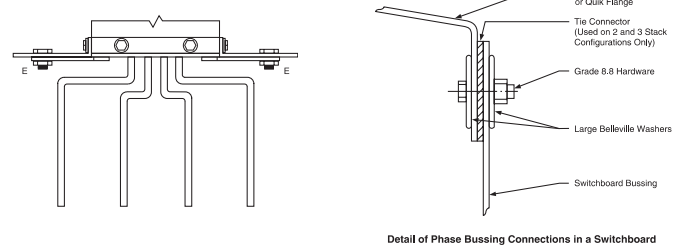

Rating (A)	Figure	Dimension (mm)			
		A	B	C	D
630	1	64	-	-	-
800	1	64	-	-	-
1000	1	64	-	-	-
1250	1	76	-	-	-
1350	1	86	-	-	-
1600	1	102	-	-	-
2000	1	127	-	-	-
2500	4	178	-	-	100
3200	2	114	289	60	-
4000	2	152	378	73	-
5000	3	114	565	111	-
6300	3	152	604	73	-

Flexible link

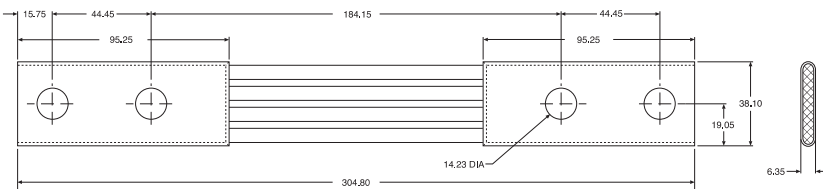

Rating (A)	3L+PE		3L+N+PE	
	Catalogue No.	No. of Pieces included	Catalogue No.	No. of Pieces included
800	FLEX308	2x3	FLEX508	2x4
1000	FLEX310	3x3	FLEX510	3x4
1250	FLEX312	3x3	FLEX512	3x4
1350	FLEX313	4x3	FLEX513	4x4
1600	FLEX316	4x3	FLEX516	4x4
2000	FLEX320	5x3	FLEX520	5x4
2500	FLEX325	7x3	FLEX525	7x4
3200	FLEX332	8x3	FLEX532	8x4
4000	FLEX340	10x3	FLEX540	10x4
5000	FLEX350	13x3	FLEX550	13x4

Ordering

Complete the catalogue number by replacing “●●” by the rating and protection degree.

Example:

Generic catalogue number of 1000 A end cable tap box, 3L+N+PE:

CFD2510GETBM54

Rating Protection degree

Discrete catalogue number example of a 10 inch, 1000A end cable tap box, 3L+N+PE:

CFD2510G10ETBBM54

Rating ●● ★ Protection degree

●● - the length of the straight feeder of end cable tap box
★ = B or S. B - with joint pak, S - without joint pak

Cable tap box - end

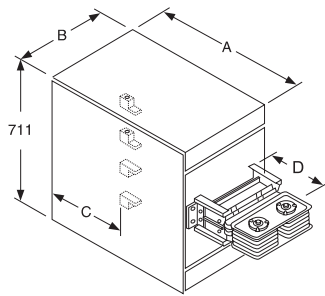

Type	Rating (A)	Cat. no		
		3L + PE	3L + N + PE(integral)	3L + N + PE(internal)
Standard	All	CFD23●●GETB*M●●	CFD25●●GETB*M●●	CFD26●●GGETB*M●●
Made to measure	630	CFD2306G●●ETB*M●●	CFD2506G●●ETB*M●●	CFD2606G●●ETB*M●●
	800	CFD2308G●●ETB*M●●	CFD2508G●●ETB*M●●	CFD2608G●●ETB*M●●
	1000	CFD2310G●●ETB*M●●	CFD2510G●●ETB*M●●	CFD2610GG●●ETB*M●●
	1250	CFD2312G●●ETB*M●●	CFD2512G●●ETB*M●●	CFD2612GG●●ETB*M●●
	1350	CFD2313G●●ETB*M●●	CFD2513G●●ETB*M●●	CFD2613GG●●ETB*M●●
	1600	CFD2316G●●ETB*M●●	CFD2516G●●ETB*M●●	CFD2616GG●●ETB*M●●
	2000	CFD2320G●●ETB*M●●	CFD2520G●●ETB*M●●	CFD2620GG●●ETB*M●●
	2500	CFD2325G●●ETB*M●●	CFD2525G●●ETB*M●●	CFD2625GG●●ETB*M●●
	3200	CFD2332G●●ETB*M●●	CFD2532G●●ETB*M●●	CFD2632GG●●ETB*M●●
	4000	CFD2340G●●ETB*M●●	CFD2540G●●ETB*M●●	CFD2640GG●●ETB*M●●
	5000	CFD2350G●●ETB*M●●	CFD2550G●●ETB*M●●	CFD2650GG●●ETB*M●●
	6300	CFD2363G●●ETB*M●●	CFD2563G●●ETB*M●●	CFD2663GG●●ETB*M●●

Dimension

Type	Rating (A)	Lugs per PH&N	Earth lugs			Dimension (mm)			
			300 mm ²	150 mm ²	300 mm ²	A	B	C	D
Standard (Min)	630	3	3	-	740	279	406	254	
	800	3	3	-	740	279	406	254	
	1000	3	3	-	740	279	406	254	
	1250	4	4	-	740	279	406	254	
	1350	4	4	-	740	279	406	254	
	1600	5	5	-	740	378	406	254	
	2000	6	-	3	740	378	406	254	
	2500	8	-	4	1000	530	660	254	
	3200	10	-	5	1000	530	660	254	
	4000	12	-	6	1000	530	660	254	
	5000	15	-	8	1000	756	660	254	
6300	17	-	9	1000	756	660	254		
Made to measure	All				min	min	min	min~ 1219	

Cable tap box- center

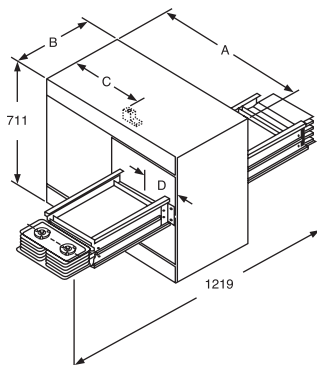

Type	Ampere rating	Cat. no		
		3L + PE	3L + N + PE(integral)	3L + N + PE(internal)
Standard	all	CFD23●●GCTBM●●	CFD25●●GCTBM●●	CFD26●●GGCTBM●●

Dimension

Type	Rating (A)	Lugs per PH&N	Earth lugs			Dimension (mm)			
			300 mm ²	150 mm ²	300 mm ²	A	B	C	D
Standard (Min)	630	3	3	-	889	356	406	185	
	800	3	3	-	889	356	406	185	
	1000	3	3	-	889	356	406	185	
	1250	4	4	-	889	356	406	185	
	1350	4	4	-	889	356	406	185	
	1600	5	5	-	889	356	406	185	
	2000	6	-	3	889	356	406	185	
2500	8	-	4	1059	508	447	261		

Note: please contact us for the ratings not shown above

Ordering

Complete the catalogue number by replacing “●●” by the rating and protection degree.

Example:

Generic catalogue number of a 3200 A end feed unit 3L+N+PE:

CFD2532GFETM54

Rating Protection degree

TL type feed unit for dry type transformer

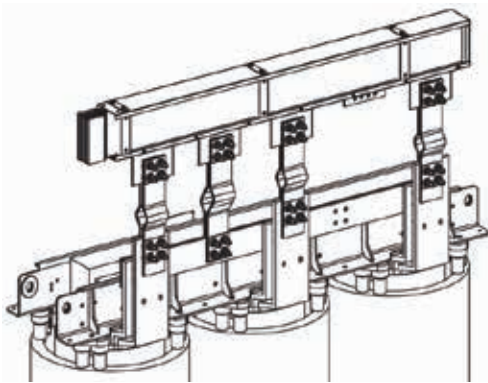

Cat. no	
3L + N + PE(integral)	3L + N + PE(internal)
CFD25●●GFETM●●	CFD26●●GFETM●●

Note: Flexible link and Adapter box are not included. Please contact Schneider local office to order.

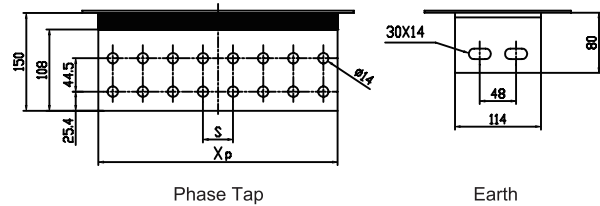
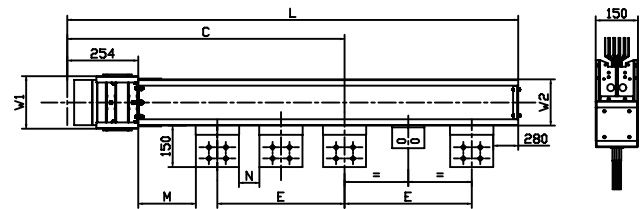

Flange details

Rating	S●●	Xp	W1	W2
630	S2	76	98	71
800	S2	76	98	71
1000	S4	76	98	71
1250	S4	76	111	84
1350	S4	101	120	93
1600	S4	114	136	109
2000	S6	137	162	135
2500	S8	203	212	185
3200	S8	203	324	297
4000	S10	203	412	385
5000	S12	254	600	573
6300	S16	305	638	611

●●-array of holes on each single tap

Overall dimensions

Rating	Dimensions(mm)				
(A)	M	Nmin	L	E	S
630 to 6300	160 to 300	55	1500 to 2600	375 to 728	40

Dimension "E" is based on the clearance of phase tap of transformer

TT type feed unit for dry type transformer

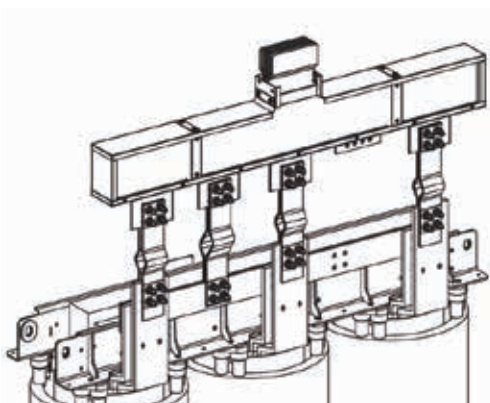

Cat. no	
3L + N + PE(integral)	3L + N + PE(internal)
CFD25●●GFETM●●	CFD26●●GFETM●●

I-LINE II Copper Busway

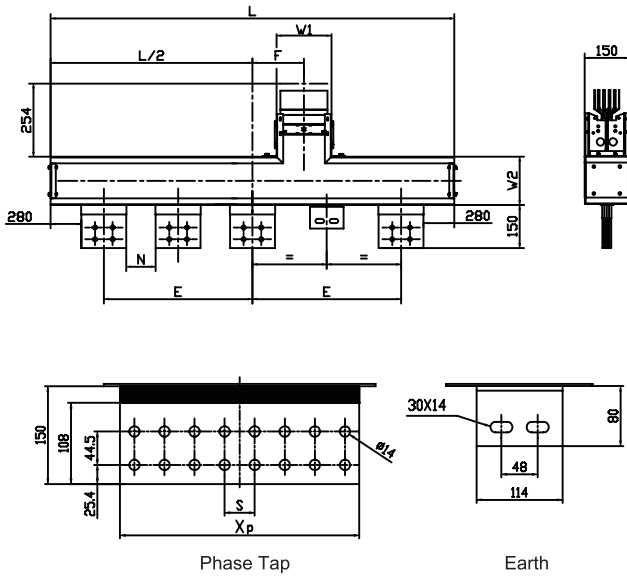

Overall dimensions

Rating (A)	Dimensions(mm)				
	F	Nmin	L	E	S
630 to 6300	160 to 300	55	1380 to 2600	375 to 728	40

Dimension "E" is based on the clearance of phase tap of transformer

Flange details

Rating	S●●	Xp	W1	W2
630	S2	76	98	71
800	S2	76	98	71
1000	S4	76	98	71
1250	S4	76	111	84
1350	S4	101	120	93
1600	S4	114	136	109
2000	S6	137	162	135
2500	S8	203	212	185
3200	S8	203	324	297
4000	S8	203	412	385
5000	S12	254	600	573
6300	S16	305	638	611

●●-array of holes on each single tap

Angle bracket for TL&TT feed unit

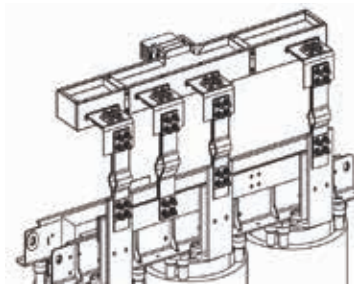
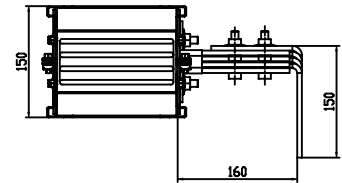
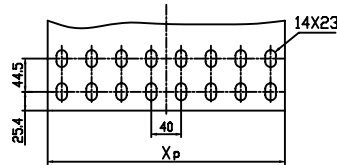
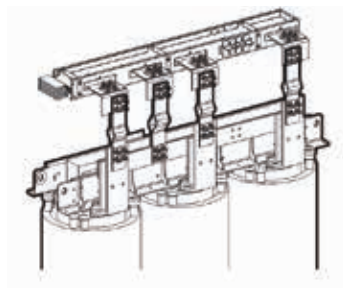

Cat. no.

3L + N + PE(integral)

3L + N + PE(internal)

CFD25●●GFETM●●

CFD26●●GFETM●●

For dimension, refer to TL or TT type.

Protective cover for feed unit

Protective cover will be designed in accordance with the way that end feed unit is mounted on. Please contact Schneider Electric for more information.

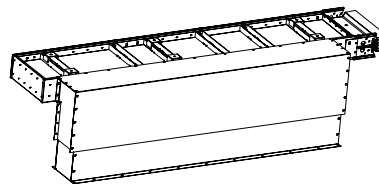
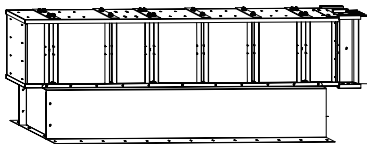

I-LINE II Copper Busway

Flatwise horizontal hanger

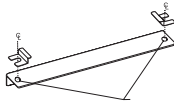
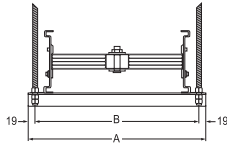
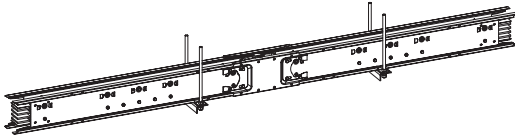

Type	Rating (A)	Dimension (mm)		Cat.no.
		A(mm)	B(mm)	
Flatwise horizontal hanger	630	186	148	HF38F
	800	186	148	HF38F
	1000	186	148	HF38F
	1250	199	161	HF43F
	1350	209	170	HF47F
	1600	225	186	HF53F
	2000	250	212	HF63F
	2500	301	263	HF83F
	3200	412	374	HF13F
	4000	501	463	HF16F
	5000	688	650	HF24F
	6300	726	688	HF25F

Edgewise horizontal hanger

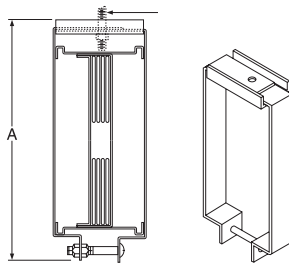
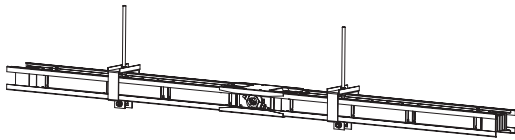

Type	Rating (A)	Dimension (mm)	Cat.no.
		A(mm)	
Edgewise horizontal hanger	630	212	HF43E
	800	212	HF43E
	1000	212	HF43E
	1250	212	HF43E
	1350	234	HF47E
	1600	250	HF58E
	2000	276	HF67E
	2500	327	HF83E
	3200	438	HF13E
	4000	527	HF16E
	5000	714	HF24E
	6300	752	HF26E

Catalogue numbers and dimensions

I-LINE II Copper Busway

Vertical fixed hanger

Type	Rating (A)	Cat.no.
Vertical fixed hanger	all	HFV

Channel, Hardware to secure channel to floor and hanger to channel not supplied.

244

28

Housing width

28

51

Finished floor or curb

Dimensions: Millimeters

Note: Allow 13.25 inches (337 mm) above curb or floor to ϕ of joint for proper installation of tie channel cover.

Catalog Number HFV

Vertical spring hanger

Type	Rating (A)	Cat.no.
Vertical Spring hanger	630	HFVS1
	800	HFVS1
	1000	HFVS1
	1250	HFVS1
	1350	HFVS1
	1600	HFVS1
	2000	HFVS2
	2500	HFVS2
	3200	HFVS8
	4000	HFVS8
5000	HFVS8	
6300	HFVS8	

244

28

Housing width

28

51

Finished floor or curb

Dimensions: Millimeters

Note: Allow 21 inches (533 mm) above curb to ϕ of joint for proper installation of tie channel cover.

HFVS1

HFVS8

HFVS2

square hole, 14mm

244

28

Housing width

28

51

152

51

Finished floor or curb

Dimensions: Millimeters

Note: Allow 21 inches (533 mm) above curb to ϕ of joint for proper installation of tie channel cover.

Catalogue numbers and dimensions

Catalogue Numbers and Dimensions

I-LINE II Copper Contact Busway

Straight Length	59
Straight Length Components	60
Elbow	62
Flanged End	67
Cable Tap Box	69
Feed Unit for Dry Type Transformer	70
Support and Fixings	72

Plug-in Unit **74**

I-LINE II Copper Contact Busway

Ordering

Complete the catalogue number by replacing “●●” by the rating and protection degree.

Example:

Generic catalogue number of 1000 A straight feeder, 3L+N+PE:

BFC2510GM54

Rating Protection degree

Discrete catalogue number of a 10 feet 1000A straight feeder, 3L+N+PE:

BFC2510G10STM54

Rating * * Protection degree

* * = the length of the straight feeder. If the number is larger than 10, the unit is inch. otherwise, the unit is feet.

Straight feeder length

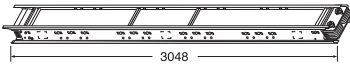

Type	Length“L”	Cat. no.		
		3L + PE	3L + N + PE(integral)	3L + N + PE(internal)
Fixed	10 Feet	BFC23●●G10STM●●	BFC25●●G10STM●●	BFC26●●GG10STM●●
Made to measure	16 inches~ 119 inches	BFC23●●G**STM●●	BFC25●●G**STM●●	BFC26●●GG**STM●●

Straight length with plug-in openings



* 10FT maximum 3 positions



* 6FT maximum 2 positions



* 4FT maximum 1 position

Example:

BRC2510G10S2P024M54 (PIO on one side, total 2 PIO, position 2, 4)
 BRC2510G10S6P135M54 (PIO on both side, total 6 PIO, position 1, 3, 5)

"S" - the total quantity of plug-in openings
 "P" - the specific position of plug-in openings

Type	Length	Number of opening (Nos x sides)	Cat. no		
			3L + PE	3L + N + PE(integral)	3L + N + PE(internal)
Plug-in	4 feet	1x2	BPC23●●G4S2P00●●M●●	BPC25●●G4S2P00●●M●●	BPC26●●GG4S2P00●●M●●
		2x2	BPC23●●G6S2P00●●M●●	BPC25●●G6S2P00●●M●●	BPC26●●GG6S2P00●●M●●
	6 feet	1x2	BPC23●●G6S4P0●●M●●	BPC25●●G6S4P0●●M●●	BPC26●●GG6S4P0●●M●●
		2x2	BPC23●●G10S2P00●●M●●	BPC25●●G10S2P00●●M●●	BPC26●●GG10S2P00●●M●●
		2x2	BPC23●●G10S4P0●●M●●	BPC25●●G10S4P0●●M●●	BPC26●●GG10S4P0●●M●●
		3x2	BPC23●●G10S6P●●●M●●	BPC25●●G10S6P●●●M●●	BPC26●●GG10S6P●●●M●●
Riser	4 feet	1x1	BRC23●●G4S1P00●●M●●	BRC25●●G4S1P00●●M●●	BRC26●●GG4S1P00●●M●●
		2x1	BRC23●●G6S1P00●●M●●	BRC25●●G6S1P00●●M●●	BRC26●●GG6S1P00●●M●●
	6 feet	1x1	BRC23●●G6S2P0●●M●●	BRC25●●G6S2P0●●M●●	BRC26●●GG6S2P0●●M●●
		2x1	BRC23●●G10S1P00●●M●●	BRC25●●G10S1P00●●M●●	BRC26●●GG10S1P00●●M●●
		2x1	BRC23●●G10S2P0●●M●●	BRC25●●G10S2P0●●M●●	BRC26●●GG10S2P0●●M●●
		3x1	BRC23●●G10S3P●●●M●●	BRC25●●G10S3P●●●M●●	BRC26●●v10S3P●●●M●●

Trunking cross-section

Rating(A)	Type	800	1000	1250	1350	1600	2000	2500	3200	4000	5000
Weight (kg/m)	3L+PE Feeder	13.0	14.2	15.9	16.5	18.0	20.5	28.4	33.2	44.8	50.4
	Plug-in	15.8	17.3	18.8	19.6	21.2	23.6	31.5	36.3	47.0	53.6
	3L+N+PE Feeder	14.0	15.6	17.8	18.6	20.5	23.5	33.5	39.7	51.8	60.1
	Plug-in	17.2	18.8	21.0	21.7	23.7	26.6	36.6	42.8	55.0	63.2
W(mm)		98	120	148	161	186	225	323	412	566	650
Figure		A	A	A	A	A	A	B	B	C	C

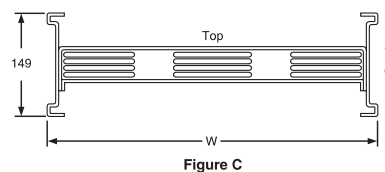
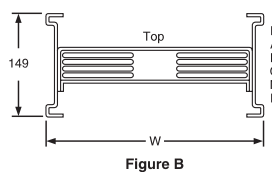
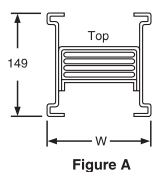

Cross Sections - Plug-In and Indoor Feeder Straight Length (IP-40 and IP-54)

I-LINE II Copper Contact Busway

Ordering

Complete the catalogue number by replacing “●●” by the rating and protection degree.

Example:

Generic catalogue number of 1000 A expansion joint, 3L+N+PE:

BFC2510GEJM54

Rating Protection degree

Discrete catalogue number of a standard 1000A expansion joint, 3L+N+PE:

BFC2510GEJM54

Rating Protection degree

Expansion joint

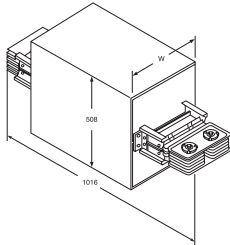

Type	Cat. no.		
	3L + PE	3L + N + PE(integral)	3L + N + PE(internal)
Fixed	BFC23●●GEJM●●	BFC25●●GEJM●●	BFC26●●GGEJM●●

Type	Length (mm)	Height (mm)	Width (mm)									
			800	1000	1250	1350	1600	2000	2500	3200	4000	5000
Fixed	1016	508	343	343	441	441	441	441	492	594	819	819

Phase transition

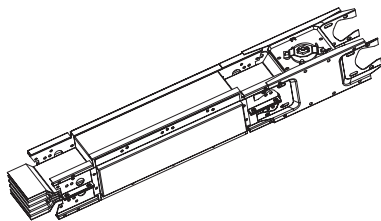

Type	Length (mm)	Cat. no.		
		3L + PE	3L + N + PE(integral)	3L + N + PE(internal)
Fixed	966	BFC23●●G38PTM●●	BFC25●●G38PTM●●	BFC26●●GG38PTM●●

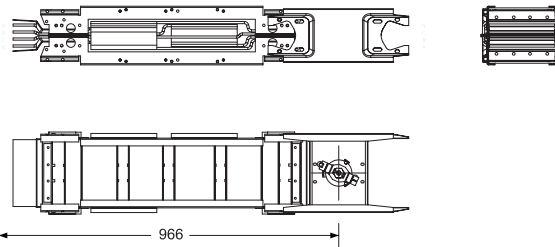

Unfused reducer

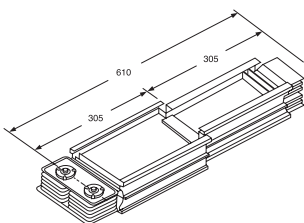

Type	Length (mm)	Cat. no.		
		3L + PE	3L + N + PE(integral)	3L + N + PE(internal)
Fixed	610	BFC23●●GR●●M●●	BFC25●●GR●●M●●	BFC26●●GGR●●M●●

Note: Replace R●● with below code. For example, BFC2520GR10M54.

Bolt side										
Ampere Rating	800	1000	1250	1350	1600	2000	2500	3200	4000	
800	-	-	-	-	-	-	-	-	-	-
1000	R08	-	-	-	-	-	-	-	-	-
1250	R08	R10	-	-	-	-	-	-	-	-
1350	R08	R10	R12	-	-	-	-	-	-	-
1600	R08	R10	R12	R13	-	-	-	-	-	-
2000	R08	R10	R12	R13	R16	-	-	-	-	-
2500	-	R10	R12	R13	R16	R20	-	-	-	-
3200	-	-	R12	R13	R16	R20	R25	-	-	-
4000	-	-	-	R13	R16	R20	R25	R32	-	-
5000	-	-	-	-	R16	R20	R25	R32	R40	-

Note: MCCB reducers are available. Contact us for details.

I-LINE II Copper Contact Busway

End closure

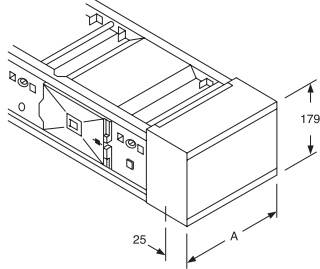

Type	Rating (A)	Dimension (mm)		Cat.no.
		A		
End closure	800	110		ACF38ECM●●
	1000	133		ACF47ECM●●
	1250	161		ACF58ECM●●
	1350	174		ACF63ECM●●
	1600	199		ACF73ECM●●
	2000	237		ACF88ECM●●
	2500	336		ACF13ECM●●
	3200	425		ACF17ECM●●
	4000	579		ACF22ECM●●
	5000	663		ACF26ECM●●

Note: please add the suffix M●● for higher protection degree. For example, ACF38ECM54

Wall and floor flange(WF)

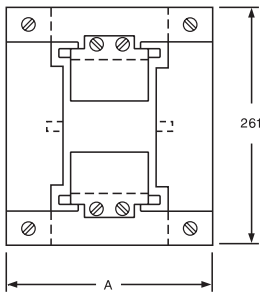

Wall and Floor Flange

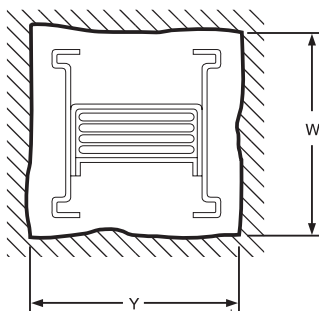

Required Wall and Floor Openings

Rating (A)	Straight Length			Flanged End		Cat.no.
	A(mm)	Y	W	Y	W	
800	211	152	229	254	381	ACF38WF
1000	233	174	229	276	381	ACF47WF
1250	262	203	229	305	381	ACF58WF
1350	275	203	229	330	381	ACF63WF
1600	300	229	229	356	381	ACF73WF
2000	338	279	229	432	533	ACF88WF
2500	437	381	229	483	533	ACF13WF
3200	526	457	229	584	533	ACF17WF
4000	679	620	229	722	533	ACF22WF
5000	764	711	229	813	533	ACF26WF

Rating (A)	Flatwise Elbow Wall thickness(mm)											
	100		200		300		400		500		600	
	W(mm)			Y(mm)			W(mm)			Y(mm)		
800	203	229	279	330	381	432	483					
1000	203	305	356	406	457	508	559					
1250	203	305	356	406	457	508	559					
1350	203	330	381	432	483	533	584					
1600	203	356	406	457	508	559	610					
2000	203	432	483	533	584	635	686					
2500	203	559	610	660	711	762	813					
3200	203	686	737	787	838	889	940					
4000	203	1016	1067	1118	1168	1219	1270					
5000	203	1016	1067	1118	1168	1219	1270					

Rating (A)	Edgewise Elbow Wall thickness(mm)											
	100		200		300		400		500		600	
	Y(mm)			W(mm)			Y(mm)			W(mm)		
800	152	305	356	406	457	509	559					
1000	178	305	356	406	457	509	559					
1250	203	305	356	406	457	509	559					
1350	203	305	356	406	457	509	559					
1600	229	305	356	406	457	509	559					
2000	279	305	356	406	457	509	559					
2500	381	305	356	406	457	509	559					
3200	457	305	356	406	457	509	559					
4000	711	305	356	406	457	509	559					
5000	711	305	356	406	457	509	559					

Ordering

Complete the catalogue number by replacing “●●” by the rating and protection degree.

Example:

Generic catalogue number of 1000A flatwise elbow, 3L+N+PE :

BFC2510GELM54

Rating Protection degree

Discrete catalogue number of a 24 inch, 1000A flatwise elbow, 3L+N+PE:

BFC2510G24LFS13B11M54

Rating ●● ●● ●● Protection degree

S - the elbow side without joint pak
B - the elbow side with joint pak

- - the length of the elbow side with joint pak
- - the length of the elbow side without joint pak
- - the total length of elbow

Flatwise elbow

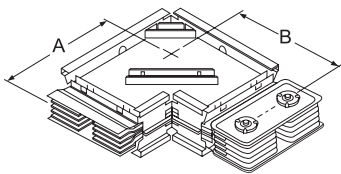

Type	Rating (A)	Cat. no		
		3L+PE	3L+N+PE(integral)	3L+N+PE(internal)
Standard	800	BFC2308G22LFS11B11M●●	BFC2508G22LFS11B11M●●	BFC2608GG22LFS11B11M●●
	1000	BFC2310G22LFS11B11M●●	BFC2510G22LFS11B11M●●	BFC2610GG22LFS11B11M●●
	1250	BFC2312G24LFS12B12M●●	BFC2512G24LFS12B12M●●	BFC2612GG24LFS12B12M●●
	1350	BFC2313G24LFS12B12M●●	BFC2513G24LFS12B12M●●	BFC2613GG24LFS12B12M●●
	1600	BFC2316G26LFS13B13M●●	BFC2516G26LFS13B13M●●	BFC2616GG26LFS13B13M●●
	2000	BFC2320G26LFS13B13M●●	BFC2520G26LFS13B13M●●	BFC2620GG26LFS13B13M●●
	2500	BFC2325G30LFS15B15M●●	BFC2525G30LFS15B15M●●	BFC2625GG30LFS15B15M●●
	3200	BFC2332G34LFS17B17M●●	BFC2532G34LFS17B17M●●	BFC2632GG34LFS17B17M●●
	4000	BFC2340G42LFS21B21M●●	BFC2540G42LFS21B21M●●	BFC2640GG42LFS21B21M●●
	5000	BFC2350G44LFS22B22M●●	BFC2550G44LFS22B22M●●	BFC2650GG44LFS22B22M●●
Made to measure	All	BFC23●●G●●LFS●●B●●M●●	BFC25●●G●●LFS●●B●●M●●	BFC26●●GG●●LFS●●B●●M●●

●●=●●●●

Dimension

Type	Rating (A)	Dimension (mm)	
		A	B
Standard (min)	800	279	279
	1000	279	279
	1250	305	305
	1350	305	305
	1600	330	330
	2000	330	330
	2500	381	381
	3200	432	432
	4000	533	533
5000	559	559	
Made to measure	All	min ~ 1219	min ~ 1219

Flatwise elbow with made to measure angle

Type	Rating	Angle W	Cat. no		
			3L + PE	3L + N + PE(integral)	3L + N + PE(internal)
Made to measure	All	91~179	BFC23●●G●●LFOAS●●B●●A●●M●●	BFC25●●G●●LFOAS●●B●●A●●M●●	BFC26●●GG●●LFOAS●●B●●A●●M●●

●●=●●●●, A●●=A+angle

Example - BFC2532G34LFOAS17B17A135M54

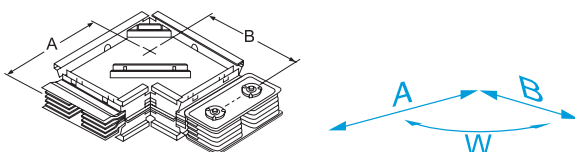

I-LINE II Copper Contact Busway

Edgewise elbow

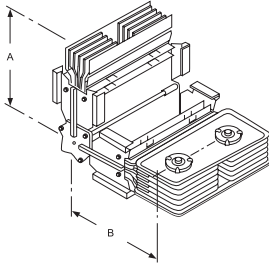

Type	Rating (A)	Cat. no		
		3L+PE	3L+N+PE(integral)	3L+N+PE(internal)
Standard	800	BFC2308G22LES11B11M●●	BFC2508G22LES11B11M●●	BFC2608GG22LES11B11M●●
	1000	BFC2310G22LES11B11M●●	BFC2510G22LES11B11M●●	BFC2610GG22LES11B11M●●
	1250	BFC2312G22LES11B11M●●	BFC2512G22LES11B11M●●	BFC2612GG22LES11B11M●●
	1350	BFC2313G22LES11B11M●●	BFC2513G22LES11B11M●●	BFC2613GG22LES11B11M●●
	1600	BFC2316G22LES11B11M●●	BFC2516G22LES11B11M●●	BFC2616GG22LES11B11M●●
	2000	BFC2320G22LES11B11M●●	BFC2520G22LES11B11M●●	BFC2620GG22LES11B11M●●
	2500	BFC2325G22LES11B11M●●	BFC2525G22LES11B11M●●	BFC2625GG22LES11B11M●●
	3200	BFC2332G22LES11B11M●●	BFC2532G22LES11B11M●●	BFC2632GG22LES11B11M●●
	4000	BFC2340G22LES11B11M●●	BFC2540G22LES11B11M●●	BFC2640GG22LES11B11M●●
Made to measure	All	BFC23●●G●●LES●●B●●M●●	BFC25●●G●●LES●●B●●M●●	BFC26●●GG●●LES●●B●●M●●

Dimension

Type	Rating (A)	Dimensions (mm)	
		A	B
Standard (min)	All	279	279
Made to measure	All	min ~ 1219	min ~ 1219

Edgewise elbow with made to measure angle



Type	Rating	Angle W	Cat. no		
			3L+PE	3L+N+PE(integral)	3L+N+PE(internal)
Made to measure	All	91~179	BFC23●●G●●LEOAS●●B●●A●●M●●	BFC25●●G●●LEOAS●●B●●A●●M●●	BFC26●●G●●LEOAS●●B●●A●●M●●

●●=●●+●●, A●●=A+angle
 Example-BFC2532G24LEOAS12B12A135M54

Flatwise tee

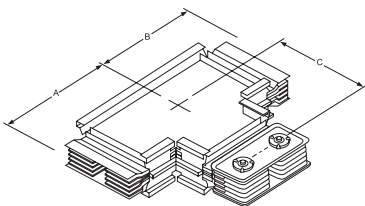

Type	Rating (A)	Cat. no		
		3L+PE	3L+N+PE(integral)	3L+N+PE(internal)
Standard	800	BFC2308G33TFS11B11S11M●●	BFC2508G33TFS11B11S11M●●	BFC2608GG33TFS11B11S11M●●
	1000	BFC2310G33TFS11B11S11M●●	BFC2510G33TFS11B11S11M●●	BFC2610GG33TFS11B11S11M●●
	1250	BFC2312G36TFS12B12S12M●●	BFC2512G36TFS12B12S12M●●	BFC2612GG36TFS12B12S12M●●
	1350	BFC2313G36TFS12B12S12M●●	BFC2513G36TFS12B12S12M●●	BFC2613GG36TFS12B12S12M●●
	1600	BFC2316G39TFS13B13S13M●●	BFC2516G39TFS13B13S13M●●	BFC2616GG39TFS13B13S13M●●
	2000	BFC2320G39TFS13B13S13M●●	BFC2520G39TFS13B13S13M●●	BFC2620GG39TFS13B13S13M●●
	2500	BFC2325G45TFS15B15S15M●●	BFC2525G45TFS15B15S15M●●	BFC2625GG45TFS15B15S15M●●
	3200	BFC2332G51TFS17B17S17M●●	BFC2532G51TFS17B17S17M●●	BFC2632GG51TFS17B17S17M●●
	4000	BFC2340G63TFS21B21S21M●●	BFC2540G63TFS21B21S21M●●	BFC2640GG63TFS21B21S21M●●
	5000	BFC2350G66TFS22B22S22M●●	BFC2550G66TFS22B22S22M●●	BFC2650GG66TFS22B22S22M●●
	Made to measure	All	BFC23●●G●●TFS●●B●●S●●M●●	BFC25●●G●●TFS●●B●●S●●M●●

Dimension

Type	Rating (A)	Dimension (mm)		
		A	B	C
Standard (min)	800	279	279	279
	1000	279	279	279
	1250	305	305	305
	1350	305	305	305
	1600	330	330	330
	2000	330	330	330
	*2500	381	381	381
	*3200	432	432	432
	*4000	533	533	533
	*5000	559	559	559
Made to measure	All	min ~ 1219	min ~ 1219	min ~ 1219

*Note: for outdoor application, the dimension of 2500/3200/4000/5000 is 406/457/559/584.

Double Elbow

I-LINE II Copper Contact Busway

Ordering

Complete the catalogue number by replacing “●●” by the rating and protection degree.

Example:

Generic catalogue number of 1000A double left elbow, 3L+N+PE :

BFC2510GELM54
 Rating Protection degree

Discrete catalogue number of a 29 inch, 1000A double left elbow, 3L+N+PE:

BFC2510G29DLB11C07SB11M54
 Rating ●● ●● ●● ●● Protection degree

- S - the elbow side without joint pak
- B - the elbow side with joint pak
- C or O - the straight feeder of the elbow
- - the total length of elbow
- - the length of the elbow side with joint pak
- - the length of straight feeder
- - the length of the elbow side without joint pak

Double left elbow

Type	Rating (A)	Cat. no		
		3L+PE	3L+N+PE(integral)	3L+N+PE(internal)
Standard	800	BFC2308G●●DLB●●C●●S●●M●●	BFC2508G●●DLB●●C●●S●●M●●	BFC2608GG●●DLB●●C●●S●●M●●
	1000	BFC2310G●●DLB●●C●●S●●M●●	BFC2510G●●DLB●●C●●S●●M●●	BFC2610GG●●DLB●●C●●S●●M●●
	1250	BFC2312G●●DLB●●C●●S●●M●●	BFC2512G●●DLB●●C●●S●●M●●	BFC2612GG●●DLB●●C●●S●●M●●
	1350	BFC2313G●●DLB●●C●●S●●M●●	BFC2513G●●DLB●●C●●S●●M●●	BFC2613GG●●DLB●●C●●S●●M●●
	1600	BFC2316G●●DLB●●C●●S●●M●●	BFC2516G●●DLB●●C●●S●●M●●	BFC2616GG●●DLB●●C●●S●●M●●
	2000	BFC2320G●●DLB●●C●●S●●M●●	BFC2520G●●DLB●●C●●S●●M●●	BFC2620GG●●DLB●●C●●S●●M●●
	2500	BFC2325G●●DLB●●C●●S●●M●●	BFC2525G●●DLB●●C●●S●●M●●	BFC2625GG●●DLB●●C●●S●●M●●
	3200	BFC2332G●●DLB●●C●●S●●M●●	BFC2532G●●DLB●●C●●S●●M●●	BFC2632GG●●DLB●●C●●S●●M●●
	4000	BFC2340G●●DLB●●C●●S●●M●●	BFC2540G●●DLB●●C●●S●●M●●	BFC2640GG●●DLB●●C●●S●●M●●
	5000	BFC2350G●●DLB●●C●●S●●M●●	BFC2550G●●DLB●●C●●S●●M●●	BFC2650GG●●DLB●●C●●S●●M●●

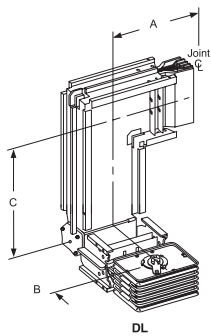

Dimension

Type	Rating (A)	Dimension (mm)		
		A	B	C
Standard (min)	800	279	279	178
	1000	279	279	178
	1250	305	279	203
	1350	305	279	203
	1600	330	279	229
	2000	330	279	229
	2500	381	279	305
	3200	432	279	356
	4000	533	279	406
	5000	559	279	635
Made to measure	All	min ~ 1219	min ~ 1219	min ~ 1016

Double right elbow

Type	Rating (A)	Cat. no		
		3L+PE	3L+N+PE(integral)	3L+N+PE(internal)
Standard	800	BFC2308G●●DRB●●C●●S●●M●●	BFC2508G●●DRB●●C●●S●●M●●	BFC2608GG●●DRB●●C●●S●●M●●
	1000	BFC2310G●●DRB●●C●●S●●M●●	BFC2510G●●DRB●●C●●S●●M●●	BFC2610GG●●DRB●●C●●S●●M●●
	1250	BFC2312G●●DRB●●C●●S●●M●●	BFC2512G●●DRB●●C●●S●●M●●	BFC2612GG●●DRB●●C●●S●●M●●
	1350	BFC2313G●●DRB●●C●●S●●M●●	BFC2513G●●DRB●●C●●S●●M●●	BFC2613GG●●DRB●●C●●S●●M●●
	1600	BFC2316G●●DRB●●C●●S●●M●●	BFC2516G●●DRB●●C●●S●●M●●	BFC2616GG●●DRB●●C●●S●●M●●
	2000	BFC2320G●●DRB●●C●●S●●M●●	BFC2520G●●DRB●●C●●S●●M●●	BFC2620GG●●DRB●●C●●S●●M●●
	2500	BFC2325G●●DRB●●C●●S●●M●●	BFC2525G●●DRB●●C●●S●●M●●	BFC2625GG●●DRB●●C●●S●●M●●
	3200	BFC2332G●●DRB●●C●●S●●M●●	BFC2532G●●DRB●●C●●S●●M●●	BFC2632GG●●DRB●●C●●S●●M●●
	4000	BFC2340G●●DRB●●C●●S●●M●●	BFC2540G●●DRB●●C●●S●●M●●	BFC2640GG●●DRB●●C●●S●●M●●
	5000	BFC2350G●●DRB●●C●●S●●M●●	BFC2550G●●DRB●●C●●S●●M●●	BFC2650GG●●DRB●●C●●S●●M●●

●●=●●+●●+●●

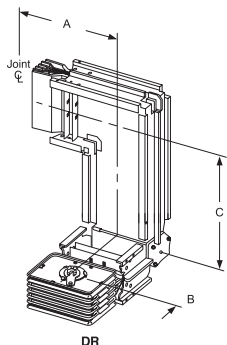

Dimension

Type	Rating (A)	Dimension (mm)		
		A	B	C
Standard (min)	800	279	279	178
	1000	279	279	178
	1250	305	279	203
	1350	305	279	203
	1600	330	279	229
	2000	330	279	229
	2500	381	279	305
	3200	432	279	356
	4000	533	279	406
	5000	559	279	635
Made to measure	All	min ~ 1219	min ~ 1219	min ~ 1016

Flatwise offset elbow

Type	Rating (A)	Cat. no		
		3L+PE	3L+N+PE(integral)	3L+N+PE(internal)
Standard	800	BFC2308G●●OFS●●O●●B●●M●●	BFC2508G●●OFS●●O●●B●●M●●	BFC2608GG●●OFS●●O●●B●●M●●
	1000	BFC2310G●●OFS●●O●●B●●M●●	BFC2510G●●OFS●●O●●B●●M●●	BFC2610GG●●OFS●●O●●B●●M●●
	1250	BFC2312G●●OFS●●O●●B●●M●●	BFC2512G●●OFS●●O●●B●●M●●	BFC2612GG●●OFS●●O●●B●●M●●
	1350	BFC2313G●●OFS●●O●●B●●M●●	BFC2513G●●OFS●●O●●B●●M●●	BFC2613GG●●OFS●●O●●B●●M●●
	1600	BFC2316G●●OFS●●O●●B●●M●●	BFC2516G●●OFS●●O●●B●●M●●	BFC2616GG●●OFS●●O●●B●●M●●
	2000	BFC2320G●●OFS●●O●●B●●M●●	BFC2520G●●OFS●●O●●B●●M●●	BFC2620GG●●OFS●●O●●B●●M●●
	2500	BFC2325G●●OFS●●O●●B●●M●●	BFC2525G●●OFS●●O●●B●●M●●	BFC2625GG●●OFS●●O●●B●●M●●
	3200	BFC2332G●●OFS●●O●●B●●M●●	BFC2532G●●OFS●●O●●B●●M●●	BFC2632GG●●OFS●●O●●B●●M●●
	4000	BFC2340G●●OFS●●O●●B●●M●●	BFC2540G●●OFS●●O●●B●●M●●	BFC2640GG●●OFS●●O●●B●●M●●
	5000	BFC2350G●●OFS●●O●●B●●M●●	BFC2550G●●OFS●●O●●B●●M●●	BFC2650GG●●OFS●●O●●B●●M●●

●●●●●●●●●●

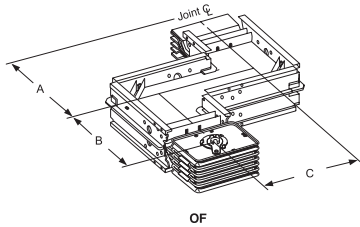

Dimension

Type	Rating (A)	Dimension (mm)		
		A	B	C
Standard (min)	800	279	279	102
	1000	279	279	102
	1250	305	305	102
	1350	305	305	152
	1600	330	330	229
	2000	330	330	254
	2500	381	381	356
	3200	432	432	406
	4000	533	533	533
	5000	559	559	635
Made to measure	All	min ~ 1219	min ~ 1219	min ~ 1016

Edgewise offset elbow

Type	Rating (A)	Cat. no		
		3L+PE	3L+N+PE(integral)	3L+N+PE(internal)
Standard	800	BFC2308G●●OES●●O●●B●●M●●	BFC2508G●●OES●●O●●B●●M●●	BFC2608GG●●OES●●O●●B●●M●●
	1000	BFC2310G●●OES●●O●●B●●M●●	BFC2510G●●OES●●O●●B●●M●●	BFC2610GG●●OES●●O●●B●●M●●
	1250	BFC2312G●●OES●●O●●B●●M●●	BFC2512G●●OES●●O●●B●●M●●	BFC2612GG●●OES●●O●●B●●M●●
	1350	BFC2313G●●OES●●O●●B●●M●●	BFC2513G●●OES●●O●●B●●M●●	BFC2613GG●●OES●●O●●B●●M●●
	1600	BFC2316G●●OES●●O●●B●●M●●	BFC2516G●●OES●●O●●B●●M●●	BFC2616GG●●OES●●O●●B●●M●●
	2000	BFC2320G●●OES●●O●●B●●M●●	BFC2520G●●OES●●O●●B●●M●●	BFC2620GG●●OES●●O●●B●●M●●
	2500	BFC2325G●●OES●●O●●B●●M●●	BFC2525G●●OES●●O●●B●●M●●	BFC2625GG●●OES●●O●●B●●M●●
	3200	BFC2332G●●OES●●O●●B●●M●●	BFC2532G●●OES●●O●●B●●M●●	BFC2632GG●●OES●●O●●B●●M●●
	4000	BFC2340G●●OES●●O●●B●●M●●	BFC2540G●●OES●●O●●B●●M●●	BFC2640GG●●OES●●O●●B●●M●●
	5000	BFC2350G●●OES●●O●●B●●M●●	BFC2550G●●OES●●O●●B●●M●●	BFC2650GG●●OES●●O●●B●●M●●

●●●●●●●●●●

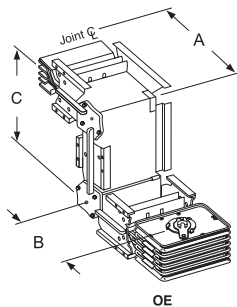

Dimension

Type	Rating (A)	Dimension (mm)		
		A	B	C
Standard (min)	All	279	279	152
Made to measure	All	min ~ 1219	min ~ 1219	min ~ 1016

Flatwise elbow flanged end

Type	Rating (A)	Cat. no.		
		3L+PE	3L+N+PE(integral)	3L+N+PE(internal)
Standard	800	BFC2308G●●LFFE*●●F●●M●●	BFC2508G●●LFFE*●●F●●M●●	BFC2608GG●●LFFE*●●F●●M●●
	1000	BFC2310G●●LFFE*●●F●●M●●	BFC2510G●●LFFE*●●F●●M●●	BFC2610GG●●LFFE*●●F●●M●●
	1250	BFC2312G●●LFFE*●●F●●M●●	BFC2512G●●LFFE*●●F●●M●●	BFC2612GG●●LFFE*●●F●●M●●
	1350	BFC2313G●●LFFE*●●F●●M●●	BFC2513G●●LFFE*●●F●●M●●	BFC2613GG●●LFFE*●●F●●M●●
	1600	BFC2316G●●LFFE*●●F●●M●●	BFC2516G●●LFFE*●●F●●M●●	BFC2616GG●●LFFE*●●F●●M●●
	2000	BFC2320G●●LFFE*●●F●●M●●	BFC2520G●●LFFE*●●F●●M●●	BFC2620GG●●LFFE*●●F●●M●●
	2500	BFC2325G●●LFFE*●●F●●M●●	BFC2525G●●LFFE*●●F●●M●●	BFC2625GG●●LFFE*●●F●●M●●
	3200	BFC2332G●●LFFE*●●F●●M●●	BFC2532G●●LFFE*●●F●●M●●	BFC2632GG●●LFFE*●●F●●M●●
	4000	BFC2340G●●LFFE*●●F●●M●●	BFC2540G●●LFFE*●●F●●M●●	BFC2640GG●●LFFE*●●F●●M●●
	5000	BFC2350G●●LFFE*●●F●●M●●	BFC2550G●●LFFE*●●F●●M●●	BFC2650GG●●LFFE*●●F●●M●●

●●●●●●●●

* = B or S.B - elbow side with joint pak, S - elbow side without joint pak

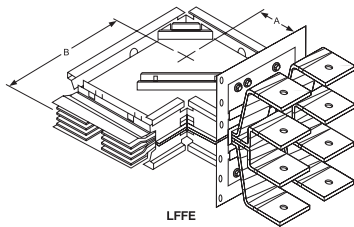

Dimension

Type	Rating (A)	Dimension (mm)	
		A	B
Standard (min)	800	204	279
	1000	204	279
	1250	204	305
	1350	229	305
	1600	229	330
	2000	254	330
	2500	305	381
	3200	356	432
	4000	457	533
	5000	457	559
Made to measure	All	min ~ 1016	min ~ 1219

Edgewise elbow flanged end

Type	Rating (A)	Cat. no.		
		3L+PE	3L+N+PE(integral)	3L+N+PE(internal)
Standard	800	BFC2308G●●LEFE*●●F●●M●●	BFC2508G●●LEFE*●●F●●M●●	BFC2608GG●●LEFE*●●F●●M●●
	1000	BFC2310G●●LEFE*●●F●●M●●	BFC2510G●●LEFE*●●F●●M●●	BFC2610GG●●LEFE*●●F●●M●●
	1250	BFC2312G●●LEFE*●●F●●M●●	BFC2512G●●LEFE*●●F●●M●●	BFC2612GG●●LEFE*●●F●●M●●
	1350	BFC2313G●●LEFE*●●F●●M●●	BFC2513G●●LEFE*●●F●●M●●	BFC2613GG●●LEFE*●●F●●M●●
	1600	BFC2316G●●LEFE*●●F●●M●●	BFC2516G●●LEFE*●●F●●M●●	BFC2616GG●●LEFE*●●F●●M●●
	2000	BFC2320G●●LEFE*●●F●●M●●	BFC2520G●●LEFE*●●F●●M●●	BFC2620GG●●LEFE*●●F●●M●●
	2500	BFC2325G●●LEFE*●●F●●M●●	BFC2525G●●LEFE*●●F●●M●●	BFC2625GG●●LEFE*●●F●●M●●
	3200	BFC2332G●●LEFE*●●F●●M●●	BFC2532G●●LEFE*●●F●●M●●	BFC2632GG●●LEFE*●●F●●M●●
	4000	BFC2340G●●LEFE*●●F●●M●●	BFC2540G●●LEFE*●●F●●M●●	BFC2640GG●●LEFE*●●F●●M●●
	5000	BFC2350G●●LEFE*●●F●●M●●	BFC2550G●●LEFE*●●F●●M●●	BFC2650GG●●LEFE*●●F●●M●●

●●●●●●●●

* = B or S. B - elbow side with joint pak, S - elbow side without joint pak

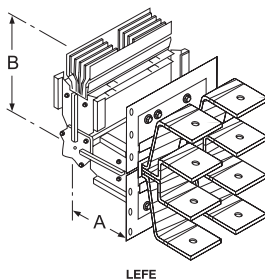

Dimension

Type	Rating (A)	Dimension (mm)	
		A	B
Standard (min)	All	152	279
Made to measure	All	min ~ 1016	min ~ 1219

Ordering

Complete the catalogue number by replacing “●●” by the rating and protection degree.

Example:

Generic catalogue number of 1000 A flanged end, 3L+N+PE:

BFC2510GFEM54
 Rating Protection degree

Discrete catalogue number example of a 12 inch, 1000A flanged end, 3L+N+PE:

BFC2510G12FEBM54
 Rating ●● * Protection degree

- - the length of the straight feeder of flanged end
- * = B or S.B - with joint pak, S - without joint pak

Flanged end unit

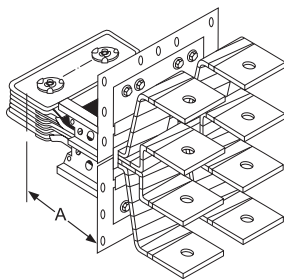

Type	Rating (A)	Cat. no.		
		3L + PE	3L + N + PE(integral)	3L + N + PE(internal)
Standard	All	BFC23●●G10FE*M●●	BFC25●●G10FE*M●●	BFC26●●GG10FE*M●●
Made to measure	800	BFC2308G●●FE*M●●	BFC2508G●●FE*M●●	BFC2608G●●FE*M●●
	1000	BFC2310G●●FE*M●●	BFC2510G●●FE*M●●	BFC2610GG●●FE*M●●
	1250	BFC2312G●●FE*M●●	BFC2512G●●FE*M●●	BFC2612GG●●FE*M●●
	1350	BFC2313G●●FE*M●●	BFC2513G●●FE*M●●	BFC2613GG●●FE*M●●
	1600	BFC2316G●●FE*M●●	BFC2516G●●FE*M●●	BFC2616GG●●FE*M●●
	2000	BFC2320G●●FE*M●●	BFC2520G●●FE*M●●	BFC2620GG●●FE*M●●
	2500	BFC2325G●●FE*M●●	BFC2525G●●FE*M●●	BFC2625GG●●FE*M●●
	3200	BFC2332G●●FE*M●●	BFC2532G●●FE*M●●	BFC2632GG●●FE*M●●
	4000	BFC2340G●●FE*M●●	BFC2540G●●FE*M●●	BFC2640GG●●FE*M●●
	5000	BFC2350G●●FE*M●●	BFC2550G●●FE*M●●	BFC2650GG●●FE*M●●

Dimension

Type	Rating (A)	Dimension (mm)
Standard (min)	All	254
Made to measure	All	min ~ 1219

Flanged Collar and Cutout and Drilling Template

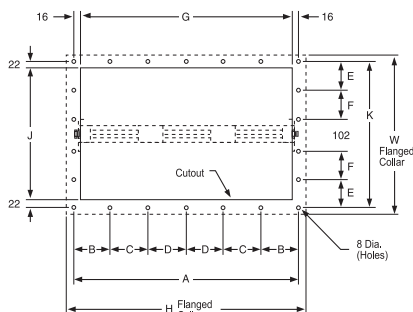

Rating (A)	Dimension (mm)			
	A	B	C	D
800	162	81	-	-
1000	203	102	-	-
1250	203	102	-	-
1350	229	114	-	-
1600	254	127	-	-
2000	327	108	-	-
2500	378	127	-	-
3200	480	121	119	-
4000	705	117	118	118
5000	705	117	118	118

Rating (A)	N Holes	Dimension (mm)							
		E	F	G	H	J	K	W	
800	10	98	-	130	187	254	296	3-Pole 326	4-Pole 335
1000	10	98	-	171	229	254	296	326	335
1250	10	98	-	171	229	254	296	326	335
1350	10	98	-	196	254	254	296	326	335
1600	10	98	-	222	279	254	296	326	335
2000	16	88	87	295	352	406	451	487	487
2500	16	88	87	346	403	406	451	487	487
3200	18	88	87	448	505	406	451	487	487
4000	22	88	87	673	730	406	451	487	487
5000	22	88	87	673	730	406	451	487	487

I-LINE II Copper Contact Busway

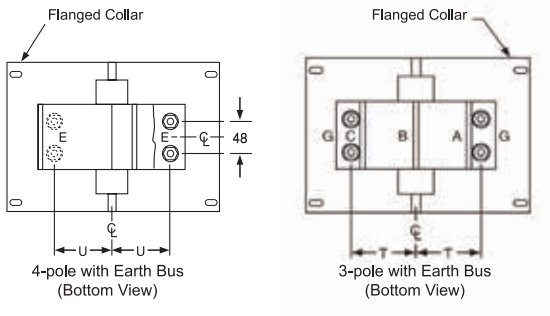

Physical Data

Rating (A)	Dimension (mm)		
	S	U	T
800	76	97	92
1000	76	97	92
1250	76	97	92
1350	76	97	92
1600	76	97	92
2000	76	173	92
2500	127	173	169
3200	127	173	169
4000	127	173	169
5000	127	173	169

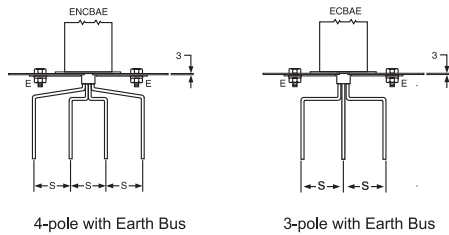

Flanged end termination details

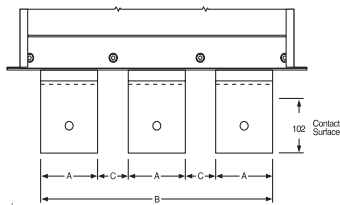
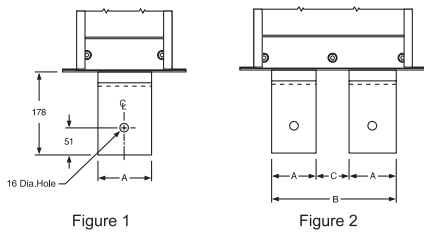
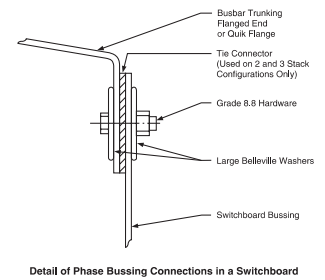
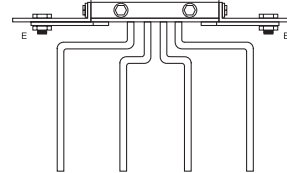

Rating (A)	Figure	Dimension (mm)		
		A	B	C
800	1	64	-	-
1000	1	86	-	-
1250	1	114	-	-
1350	1	127	-	-
1600	1	152	-	-
2000	1	191	-	-
2500	2	114	289	60
3200	2	152	378	73
4000	3	137	532	60
5000	3	165	616	60

Flexible link

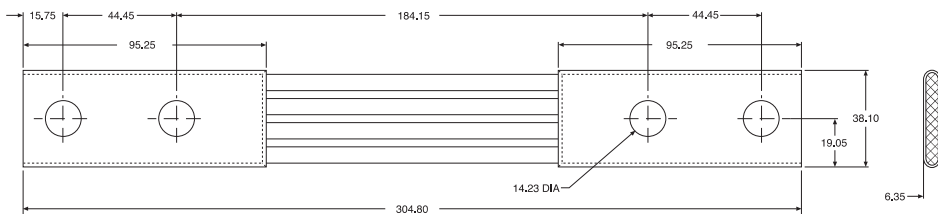

Rating (A)	3L+PE		3L+N+PE	
	Catalogue No.	No. of Pieces included	Catalogue No.	No. of Pieces included
630	FLEX306	2x3	FLEX506	2x4
800	FLEX308	2x3	FLEX508	2x4
1000	FLEX310	3x3	FLEX510	3x4
1250	FLEX312	3x3	FLEX512	3x4
1350	FLEX313	4x3	FLEX513	4x4
1600	FLEX316	4x3	FLEX516	4x4
2000	FLEX320	5x3	FLEX520	5x4
2500	FLEX325	7x3	FLEX525	7x4
3200	FLEX332	8x3	FLEX532	8x4
4000	FLEX340	10x3	FLEX540	10x4
5000	FLEX350	13x3	FLEX550	13x4
6300	FLEX363	16x3	FLEX563	16x4

Ordering

Complete the catalogue number by replacing “●●” by the rating and protection degree.

Example:

Generic catalogue number of 1000 A end cable tap box, 3L+N+PE:

BFC2510GETBM54

Rating Protection degree

Discrete catalogue number example of a 10 inch, 1000A end cable tap box, 3L+N+PE:

BFC2510G10ETBBM54

Rating ●● * Protection degree

●● - the length of the straight feeder of end cable tap box
* = B or S. B - with joint pak, S - without joint pak

Cable tap box - end

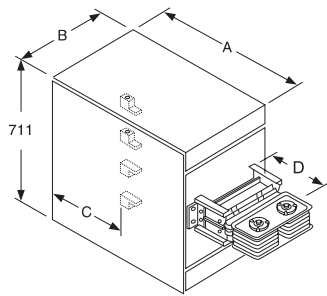

Type	Ampere rating	Cat. no.		
		3L + PE	3L + N + PE(integral)	3L + N + PE(internal)
Standard	All	BFC23●●GETB*M●●	BFC25●●GETB*M●●	BFC26●●GGETB*M●●
Made to measure	800	BFC2308G●●ETB*M●●	BFC2508G●●ETB*M●●	BFC2608G●●ETB*M●●
	1000	BFC2310G●●ETB*M●●	BFC2510G●●ETB*M●●	BFC2610G●●ETB*M●●
	1250	BFC2312G●●ETB*M●●	BFC2512G●●ETB*M●●	BFC2612G●●ETB*M●●
	1350	BFC2313G●●ETB*M●●	BFC2513G●●ETB*M●●	BFC2613G●●ETB*M●●
	1600	BFC2316G●●ETB*M●●	BFC2516G●●ETB*M●●	BFC2616G●●ETB*M●●
	2000	BFC2320G●●ETB*M●●	BFC2520G●●ETB*M●●	BFC2620G●●ETB*M●●
	2500	BFC2325G●●ETB*M●●	BFC2525G●●ETB*M●●	BFC2625G●●ETB*M●●
	3200	BFC2332G●●ETB*M●●	BFC2532G●●ETB*M●●	BFC2632G●●ETB*M●●
	4000	BFC2340G●●ETB*M●●	BFC2540G●●ETB*M●●	BFC2640G●●ETB*M●●
	5000	BFC2350G●●ETB*M●●	BFC2550G●●ETB*M●●	BFC2650G●●ETB*M●●

Dimension

Type	Rating (A)	Lugs per PH&N			Dimension (mm)				
		300mm ²	150mm ²	Earth lugs	300mm ²	A	B	C	D
						300mm ²	A	B	C
Made to measure	800	3	3	-	740	279	406	254-1219	
	1000	3	3	-	740	279	406	254-1219	
	1250	4	4	-	740	378	406	254-1219	
	1350	4	4	-	740	378	406	254-1219	
	1600	5	5	-	740	378	406	254-1219	
	2000	6	-	3	740	378	406	254-1219	
	2500	8	-	4	740	429	406	254-1219	
	3200	10	-	5	1000	530	660	254-1219	
	4000	12	-	6	1000	756	660	254-1219	
	5000	15	-	8	1000	756	660	254-1219	

Cable tap box - center

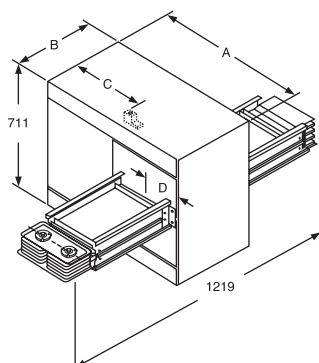

Type	Ampere rating	Cat. no.		
		3L + PE	3L + N + PE(integral)	3L + N + PE(internal)
Standard	All	BFC23●●GCTBM●●	BFC25●●GCTBM●●	BFC26●●GGCTBM●●

Dimension

Type	Rating (A)	Lugs per PH&N			Dimension (mm)				
		300mm ²	150mm ²	Earth lugs	300mm ²	A	B	C	D
						300mm ²	A	B	C
Standard	800	3	3	-	889	356	406	185	
	1000	3	3	-	889	356	406	185	
	1250	4	4	-	889	356	406	185	
	1350	4	4	-	889	356	406	185	
	1600	5	5	-	889	356	406	185	
	2000	6	-	3	889	356	406	185	
2500	8	-	4	1059	508	447	261		

Note: please contact us for the ratings not shown above

Ordering

Complete the catalogue number by replacing “●●” by the rating and protection degree.

Example:

Generic catalogue number of a 3200 A end feed unit, 3L+N+PE:

BFC2532GFETM54

Rating Protection degree

TL type feed unit for dry type transformer

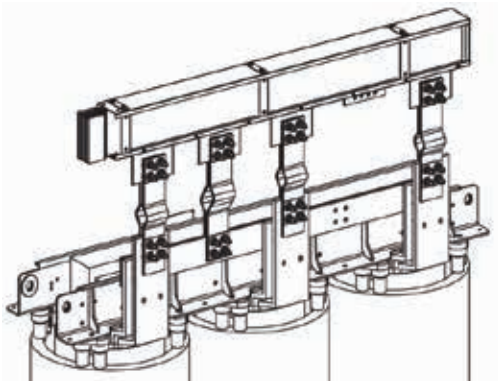

Cat. no.	
3L + N + PE(integral)	3L + N + PE(internal)
BFC25●●GFETM●●	BFT26●●GGFETM●●

Note: Flexible link and Adapter box are not included. Please contact Schneider local office to order.

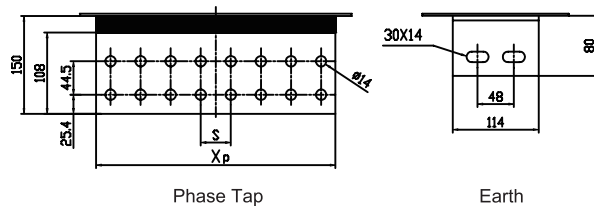
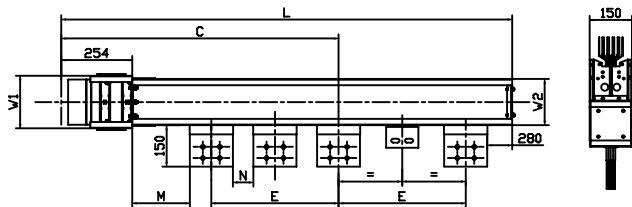

Flange details

Rating	S●●	Xp	W1	W2
800	S2	76	98	71
1000	S4	86	120	93
1250	S4	114	149	122
1350	S4	127	162	135
1600	S4	152	187	160
2000	S6	190	225	198
2500	S8	203	324	297
3200	S8	203	412	385
4000	S8	254	567	540
5000	S12	305	651	624

●● - array of holes on each single tap

Overall dimensions

Rating	Dimensions(mm)				
(A)	M	Nmin	L	E	S
800 to 5000	160 to 300	55	1500 to 2600	375 to 728	40

Dimension "E" is based on the clearance of phase tap of transformer

TT type feed unit for dry type transformer

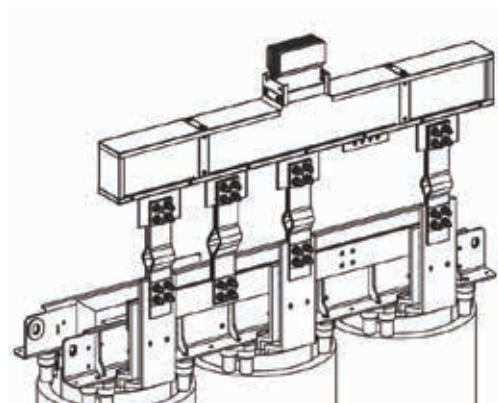

Cat. no.	
3L + N + PE(integral)	3L + N + PE(internal)
BFC25●●GFETM●●	BFC26●●GGFETM●●

I-LINE II Copper Contact Busway

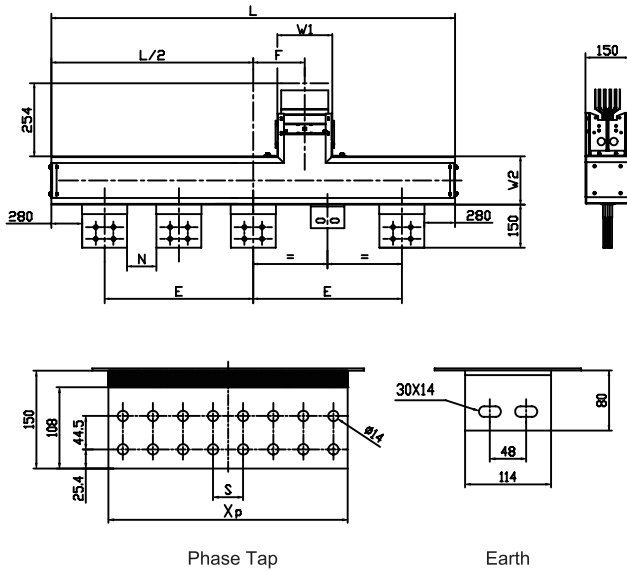

Overall dimensions

Rating	Dimensions(mm)				
(A)	F	Nmin	L	E	S
800 to 5000	160 to 300	55	1380 to 2600	375 to 728	40

Dimension "E" is based on the clearance of phase tap of transformer

Flange details

Rating	S●●	Xp	W1	W2
800	S2	76	98	71
1000	S4	86	120	93
1250	S4	114	149	122
1350	S4	127	162	135
1600	S4	152	187	160
2000	S6	190	225	198
2500	S8	203	324	297
3200	S8	203	412	385
4000	S8	254	567	540
5000	S12	305	651	624

●● - array of holes on each single tap

Angle bracket for TL&TT feed unit

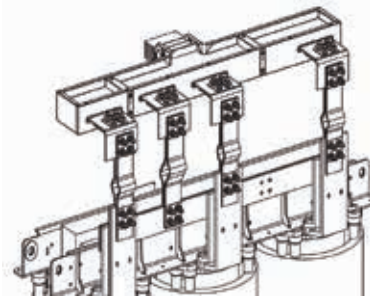
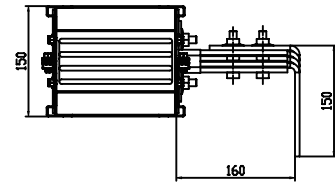
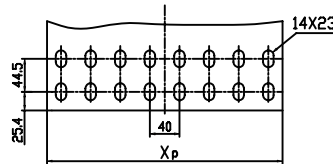
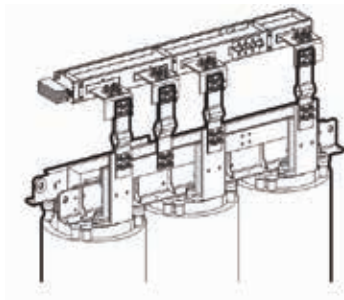

Cat. no.	3L + N + PE(integral)	3L + N + PE(internal)
BFC25●●GFETM●●		BFC26●●GGFETM●●

For dimension, refer to TL or TT type.

Protective cover for feed unit

Protective cover will be designed in accordance with the way that end feed unit is mounted on. Please contact Schneider Electric for more information.

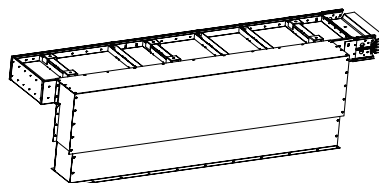
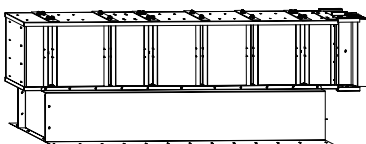

I-LINE II Copper Contact Busway

Flatwise horizontal hanger

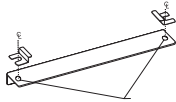
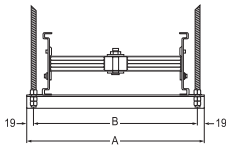
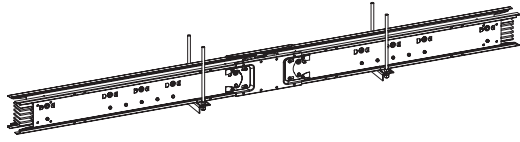

Type	Rating (A)	Dimension (mm)		Cat. no
		A(mm)	B(mm)	
Flatwise horizontal hanger	800	186	148	HF38F
	1000	209	170	HF47F
	1250	237	199	HF58F
	1350	250	212	HF63F
	1600	274	236	HF73F
	2000	312	274	HF88F
	2500	412	374	HF13F
	3200	501	463	HF16F
	4000	654	616	HF22F
	5000	739	701	HF26F

Edgewise horizontal hanger

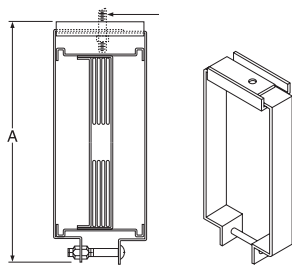
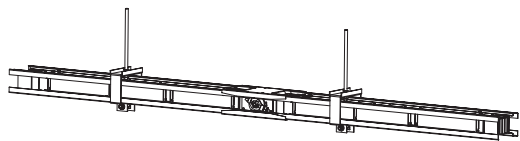

Type	Rating (A)	Dimension (mm)	Cat. no
		A(mm)	
Edgewise horizontal hanger	800	212	HF43E
	1000	234	HF47E
	1250	250	HF58E
	1350	276	HF67E
	1600	301	HF78E
	2000	339	HF88E
	2500	438	HF13E
	3200	527	HF16E
	4000	680	HF22E
	5000	752	HF26E

Catalogue numbers and dimensions

I-LINE II Copper Contact Busway

Vertical fixed hanger

Type	Rating (A)	Cat.no
Vertical fixed hanger	All	HFV

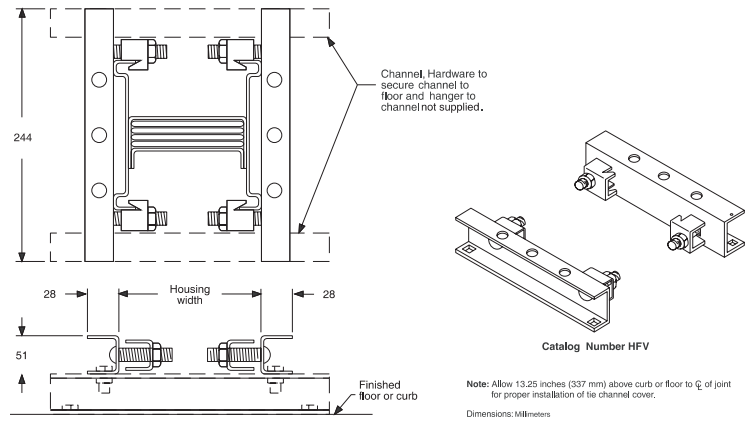

Vertical spring hanger

Type	Rating (A)	Cat.no
Vertical Spring hanger	800	HFVS1
	1000	HFVS1
	1250	HFVS1
	1350	HFVS1
	1600	HFVS1
	2000	HFVS1
	2500	HFVS2
	3200	HFVS2
	4000	HFVS8
	5000	HFVS8

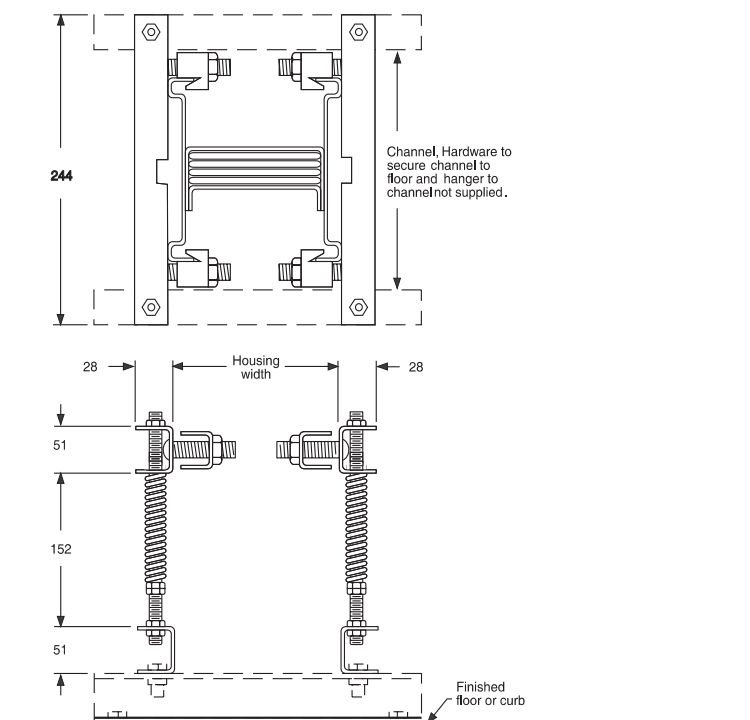
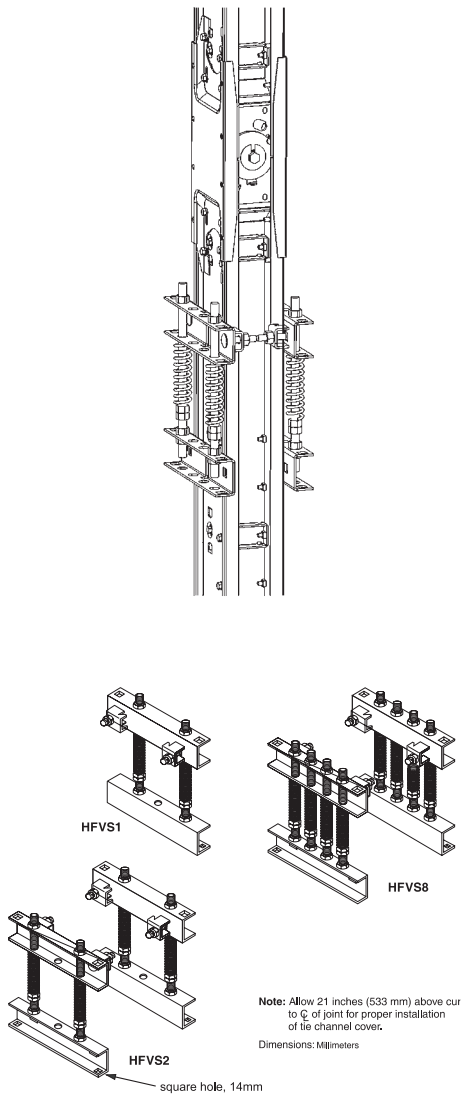

Catalogue numbers and dimensions

I-LINE Plug-in Unit

C.Plug-in unit with Schneider Electric MCCB	
Ampere Rating Reference	Code
15A-250A	P
252A-500A	PB
630A-1000A	PT
Type of breaker	Code
NSD(15A-100A)	NSD
CVSF(16A-500A)/NSXF(16A-500A)	NSEN/NSXF
CVSN(16A-500A)/NSXN(16A-500A)	NSES/NSXN
CVSH(16A-500A)/NSXH(16A-500A)	NSEH/NSXH
NSXS(16A-500A)	NSXS
NSN(630A-1000A)	NSN
NSH(630A-1000A)	NSH
Series	Code
34	34
Ampere Rating(16A-1000A)	Code
200A	200
Earthing	Code
with earth bar	G
Polarity	Code
3 pole PLU,3 pole breaker	-
4 pole PIU,3 pole breaker	N
4 pole PIU,4 pole breaker	T
Handle operation	Code
Side handle	S
Rotary handle	-
Vigi option	Code
with vigi	V
without vigi	-
IP Rating	Code
	54

P NSXF 34 200 G N S V M54

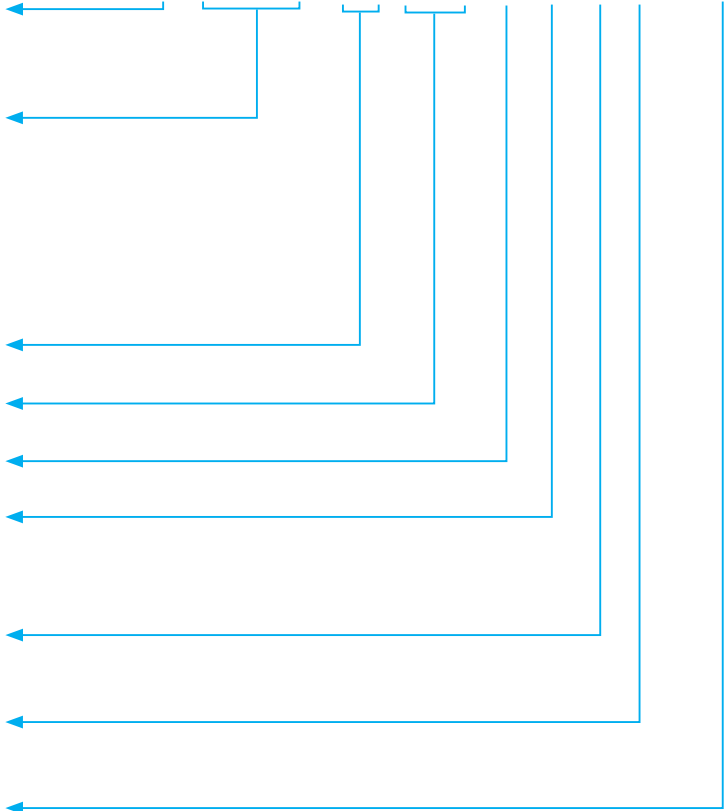

Note:For Plug-in units which ampere rating exceeds 1000A,please contact Schneider Electric local office.

Catalogue numbers and dimensions

I-LINE Plug-in Unit

Plug-in Unit with Schneider Electric MCCB (500A and below)

CVSF breaker							
Trip Rating A	Interrupting Current kA(380/415V)	Number of poles	Catalogue Number(3 poles breaker) Side handle, without Vigi	Trip Rating A	Interrupting Current kA(380/415V)	Number of poles	Catalogue Number(3 poles breaker) Side handle, without Vigi
16	36	3,4*	PNSEN34016GNS	100	36	3,4*	PNSEN34100GNS
25	36	3,4*	PNSEN34025GNS	125	36	3,4*	PNSEN34125GNS
32	36	3,4*	PNSEN34032GNS	160	36	3,4*	PNSEN34160GNS
40	36	3,4*	PNSEN34040GNS	200	36	3,4*	PNSEN34200GNS
50	36	3,4*	PNSEN34050GNS	250	36	3,4*	PNSEN34250GNS
63	36	3,4*	PNSEN34063GNS	400	36	3,4*	PBSEN34400GNS
80	36	3,4*	PNSEN34080GNS	500	36	3,4*	PBSEN34500GNS
CVSN breaker							
Trip Rating A	Interrupting Current kA(380/415V)	Number of poles	Catalogue Number(3 poles breaker) Side handle, without Vigi	Trip Rating A	Interrupting Current kA(380/415V)	Number of poles	Catalogue Number(3 poles breaker) Side handle, without Vigi
16	50	3,4*	PNSES34016GNS	100	50	3,4*	PNSES34100GNS
25	50	3,4*	PNSES34025GNS	125	50	3,4*	PNSES34125GNS
32	50	3,4*	PNSES34032GNS	160	50	3,4*	PNSES34160GNS
40	50	3,4*	PNSES34040GNS	200	50	3,4*	PNSES34200GNS
50	50	3,4*	PNSES34050GNS	250	50	3,4*	PNSES34250GNS
63	50	3,4*	PNSES34063GNS	400	50	3,4*	PBSES34400GNS
80	50	3,4*	PNSES34080GNS	500	50	3,4*	PBSES34500GNS
CVSH breaker							
Trip Rating A	Interrupting Current kA(380/415V)	Number of poles	Catalogue Number(3 poles breaker) Side handle, without Vigi	Trip Rating A	Interrupting Current kA(380/415V)	Number of poles	Catalogue Number(3 poles breaker) Side handle, without Vigi
16	70	3,4*	PNSEH34016GNS	100	70	3,4*	PNSEH34100GNS
25	70	3,4*	PNSEH34025GNS	125	70	3,4*	PNSEH34125GNS
32	70	3,4*	PNSEH34032GNS	160	70	3,4*	PNSEH34160GNS
40	70	3,4*	PNSEH34040GNS	200	70	3,4*	PNSEH34200GNS
50	70	3,4*	PNSEH34050GNS	250	70	3,4*	PNSEH34250GNS
63	70	3,4*	PNSEH34063GNS	400	70	3,4*	PBSEH34400GNS
80	70	3,4*	PNSEH34080GNS	500	70	3,4*	PBSEH34500GNS
NSD breaker							
Trip Rating A	Interrupting Current kA(380/415V)	Number of poles	Catalogue Number(3 poles breaker) Side handle, without Vigi	Trip Rating A	Interrupting Current kA(380/415V)	Number of poles	Catalogue Number(3 poles breaker) Side handle, without Vigi
15	25	3	PNSD34015GNS	50	25	3	PNSD34050GNS
20	25	3	PNSD34020GNS	60	25	3	PNSD34060GNS
25	25	3	PNSD34025GNS	75	25	3	PNSD34075GNS
30	25	3	PNSD34030GNS	80	25	3	PNSD34080GNS
40	25	3	PNSD34040GNS	100	25	3	PNSD34100GNS

*Note: For 4 poles breaker Plug-in unit, please replace the suffix GN with GT.

I-LINE Plug-in Unit

Plug-in Unit with Schneider Electric MCCB (500A and below)

NSXF Breaker							
Trip Rating A	Interrupting Current kA(380/415V)	Number of poles	Catalogue Number(3 poles breaker) Side handle, without Vigi	Trip Rating A	Interrupting Current kA(380/415V)	Number of poles	Catalogue Number(3 poles breaker) Side handle, without Vigi
16	36	3,4*	PNSXF34016GNS	100	36	3,4*	PNSXF34100GNS
25	36	3,4*	PNSXF34025GNS	125	36	3,4*	PNSXF34125GNS
32	36	3,4*	PNSXF34032GNS	160	36	3,4*	PNSXF34160GNS
40	36	3,4*	PNSXF34040GNS	200	36	3,4*	PNSXF34200GNS
50	36	3,4*	PNSXF34050GNS	250	36	3,4*	PNSXF34250GNS
63	36	3,4*	PNSXF34063GNS	400	36	3,4*	PBNSXF34400GNS
80	36	3,4*	PNSXF34080GNS	500	36	3,4*	PBNSXF34500GNS
NSXH Breaker							
Trip Rating A	Interrupting Current kA(380/415V)	Number of poles	Catalogue Number(3 poles breaker) Side handle, without Vigi	Trip Rating A	Interrupting Current kA(380/415V)	Number of poles	Catalogue Number(3 poles breaker) Side handle, without Vigi
16	50	3,4*	PNSXN34016GNS	100	50	3,4*	PNSXN34100GNS
25	50	3,4*	PNSXN34025GNS	125	50	3,4*	PNSXN34125GNS
32	50	3,4*	PNSXN34032GNS	160	50	3,4*	PNSXN34160GNS
40	50	3,4*	PNSXN34040GNS	200	50	3,4*	PNSXN34200GNS
50	50	3,4*	PNSXN34050GNS	250	50	3,4*	PNSXN34250GNS
63	50	3,4*	PNSXN34063GNS	400	50	3,4*	PBNSXN34400GNS
80	50	3,4*	PNSXN34080GNS	500	50	3,4*	PBNSXN34500GNS
NSXH Breaker							
Trip Rating A	Interrupting Current kA(380/415V)	Number of poles	Catalogue Number(3 poles breaker) Side handle, without Vigi	Trip Rating A	Interrupting Current kA(380/415V)	Number of poles	Catalogue Number(3 poles breaker) Side handle, without Vigi
16	70	3,4*	PNSXH34016GNS	100	70	3,4*	PNSXH34100GNS
25	70	3,4*	PNSXH34025GNS	125	70	3,4*	PNSXH34125GNS
32	70	3,4*	PNSXH34032GNS	160	70	3,4*	PNSXH34160GNS
40	70	3,4*	PNSXH34040GNS	200	70	3,4*	PNSXH34200GNS
50	70	3,4*	PNSXH34050GNS	250	70	3,4*	PNSXH34250GNS
63	70	3,4*	PNSXH34063GNS	400	70	3,4*	PBNSXH34400GNS
80	70	3,4*	PNSXH34080GNS	500	70	3,4*	PBNSXH34500GNS
NSXS breaker							
Trip Rating A	Interrupting Current kA(380/415V)	Number of poles	Catalogue Number Side handle, without Vigi	Trip Rating A	Interrupting Current kA(380/415V)	Number of poles	Catalogue Number(3 poles breaker) Side handle, without Vigi
16	100	3,4*	PNSXS34016GNS	100	100	3,4*	PNSXS34100GNS
25	100	3,4*	PNSXS34025GNS	125	100	3,4*	PNSXS34125GNS
32	100	3,4*	PNSXS34032GNS	160	100	3,4*	PNSXS34160GNS
40	100	3,4*	PNSXS34040GNS	200	100	3,4*	PNSXS34200GNS
50	100	3,4*	PNSXS34050GNS	250	100	3,4*	PNSXS34250GNS
63	100	3,4*	PNSXS34063GNS	400	100	3,4*	PBNSXS34400GNS
80	100	3,4*	PNSXS34080GNS	500	100	3,4*	PBNSXS34500GNS

*Note:For 4 poles breaker Plug-in unit,please replace the suffix GN with GT.

Plug-in Unit with Schneider Electric MCCB (above 500A)

NSN breaker				
Trip Rating A	Interrupting Current kA(380/415V)	Number of poles	Catalogue Number(3 poles breaker)	
			without Vigi ,Horizontal installation	without Vigi, Vertical installation
630	50	3,4*	PTNSN34630GNH	PTNSN34630GNV
800	50	3,4*	PTNSN34800GNH	PTNSN34800GNV
1000	50	3,4*	PTNSN34100GNH	PTNSN34100GNV
NSH breaker				
Trip Rating A	Interrupting Current kA(380/415V)	Number of poles	Catalogue Number(3 poles breaker)	
			Without Vigi ,Horizontal installation	Without Vigi, Vertical installation
630	70	3,4*	PTNSH34630GNH	PTNSH34630GNV
800	70	3,4*	PTNSH34800GNH	PTNSH34800GNV
1000	70	3,4*	PTNSH34100GNH	PTNSH34100GNV

*Note:For 4 poles breaker plug-in unit,please replace the suffix GN with GT.
For 3L + PE busway(3P3W),please replace the suffix GN with G.

I-LINE Plug-in Unit

Plug-in Unit with Schneider Electric MCCB

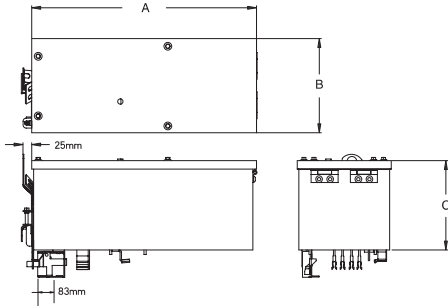

Figure1: 16-250A plug-in unit

Side handle type		Trip Rating	
		15-100A	125-250A
Plug-in Unit Dimension (A*B*C)mm	NSD	without Vigi	373x216x178
		with Vigi	448x216x178
	NSEN/NSXF/NSXN	without Vigi	373x216x178
		with Vigi	448x216x178
	NSES/NSEH/NSXH	without Vigi	516x216x198
		with Vigi	591x216x198
NSXS	without Vigi	416x216x198	
	with Vigi	591x216x198	

Rotary handle type		Trip Rating	
		15-100A	125-250A
Plug-in Unit Dimension (A*B*C)mm	without Vigi	548x216x200	548x216x200
	with Vigi	623x216x200	623x216x200
Weight of Plug-in Unit		11-12kg	15-16kg

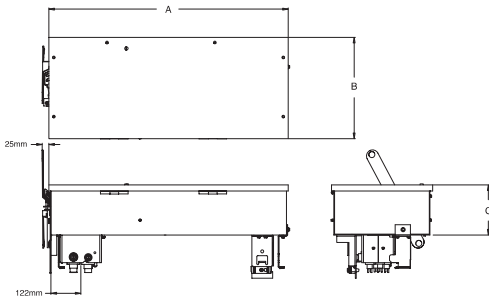

Figure2: 252-500A plug-in unit

Side handle type		Trip Rating	
		252-500A	
Plug-in Unit Dimension (A*B*C)mm	NSEN/NSXF/NSXN	without Vigi	880x372x184
		with Vigi	979x372x184
	NSES/NSEH/NSXH	without Vigi	880x372x184
		with Vigi	979x372x184
	NSXS	without Vigi	880x372x184
		with Vigi	979x372x184

Rotary handle type		Trip Rating	
		252-500A	
Plug-in Unit Dimension (A*B*C)mm	without Vigi	879X400X187	
	with Vigi	979X400X187	
Weight of Plug-in Unit		43-48kg	

Rotary handle type		Trip Rating	
		630-1000A	
Plug-in Unit Dimension (A*B*C)mm	NSEN/NSN	without Vigi	805x369x342
	NSES/NSEH/NSH	without Vigi	805x369x342
Weight of Plug-in Unit		78-80kg	

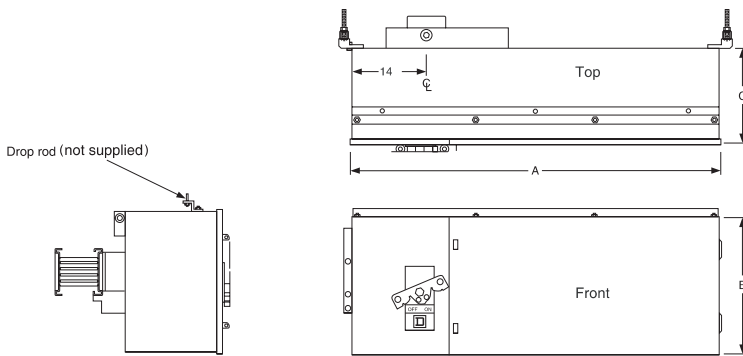
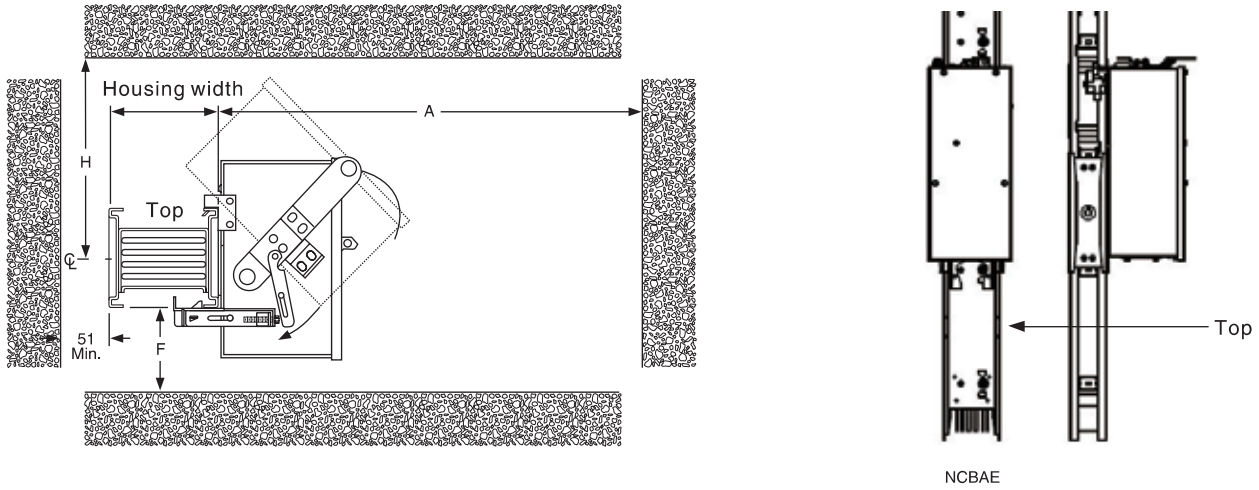

Figure3: 630-1000A plug-in unit

Catalogue numbers and dimensions

I-LINE Plug-in Unit

Required Clearance for Plug-in Mounting(Check these dimensions carefully before installing straight length)



IMPORTANT: orientation of the busbar trunking is essential for proper mounting of plug-in units. The busbar trunking must be positioned as shown above so that the top marking is to the right and the neutral position to the left.

Circuit Breaker Plug-in Unit:
Circuit breaker plug-in unit may be installed on both sides of a riser.

Plug-in Unit with Schneider Electric MCCB				
	Trip Rating(A)	A(mm)	F(mm)	H(mm)
NSD	16-100	651	60	260
NSXF,NSXN,NSXH,NSEN,NSES,NSEH	16-250	651	60	280
NSXF,NSXN,NSXH,NSEN,NSES,NSEH	125-250	651	60	280
NSXF,NSXN,NSXH,NSEN,NSES,NSEH	252-500	910	145	380
NSN,NSH,NSEN,NSES,NSEH	630-1000	932	160	406

Catalogue numbers and dimensions

Design Guide

Characteristics	80
Design with I-LINE II Busbar Trunking System	82
Harmonic Current	86
Fire Resistance	88
Measurement and Metering	90
iBusway Solution	92
Direct Current	96

I-LINE II Copper Busway

Characteristics of straight lengths

General characteristics	Symbol	Unit	Busbar trunking rating(A)										
			630	800	1000	1250	1350	1600	2000	2500	3200	4000	5000
Compliance with standards			IEC/EN 61439-6										
Protection degree	IP		41~66										
Rated insulation voltage	Ui	V	1000										
Rated operating voltage	Ue	V	1000										
Operating frequency	f	Hz	50/60										

Short-circuit current withstand

	Symbol	Unit	630	800	1000	1250	1350	1600	2000	2500	3200	4000	5000	6300
Allowable rated short-time withstand current(t=1s)	Icw	kA	40	40	45	50	50	50	60	75	80	100	120	120
Allowable rated peak current	Ipk	kA	84	84	99	110	110	110	132	165	176	220	264	264

Conductor characteristics

Phase conductors														
	Symbol	Unit	630	800	1000	1250	1350	1600	2000	2500	3200	4000	5000	6300
Average resistance at an ambient temperature of 20°C	R20	mΩ/m	0.059	0.059	0.055	0.038	0.033	0.028	0.023	0.016	0.013	0.009	0.008	0.008
Average resistance at Inc	R1	mΩ/m	0.073	0.077	0.075	0.052	0.038	0.030	0.029	0.022	0.017	0.013	0.012	0.009
Average reactance at Inc and at 50Hz	X1	mΩ/m	0.032	0.033	0.031	0.027	0.020	0.015	0.016	0.012	0.008	0.007	0.006	0.005
Average impedance at Inc and at 50Hz	Z1	mΩ/m	0.079	0.084	0.081	0.058	0.043	0.034	0.033	0.025	0.019	0.015	0.013	0.010
Protective conductor(PE)														
Average resistance at an ambient temperature of 20°C		mΩ/m	0.383	0.385	0.393	0.359	0.331	0.307	0.231	0.189	0.098	0.112	0.095	0.055

Voltage drop

Line-to-line voltage drop, in volts(V)per metre at 50 Hz with concentrated load. For the case of loads distributed over the run, the voltage drops need times the load distribution factor(see more details in page 86).														
For a cosine φ of	1	V/m	630	800	1000	1250	1350	1600	2000	2500	3200	4000	5000	6300
	0.95			0.080	0.107	0.130	0.113	0.089	0.083	0.100	0.095	0.094	0.090	0.104
0.9		0.087	0.116	0.140	0.125	0.099	0.092	0.113	0.107	0.103	0.101	0.115	0.110	
0.85		0.087	0.116	0.140	0.127	0.100	0.093	0.115	0.108	0.104	0.102	0.116	0.112	
0.8		0.086	0.115	0.139	0.126	0.100	0.093	0.115	0.108	0.103	0.102	0.116	0.112	
		0.085	0.113	0.136	0.125	0.099	0.091	0.114	0.107	0.102	0.101	0.114	0.111	

Choice of products when harmonics are present(see "harmonic currents"for more details).

Rated current according to THD3(3 rd order distortion)	THD<15%	630	800	1000	1250	1350	1600	2000	2500	3200	4000	5000	6300	
	15%< THD<33%	-	630	800	1000	1000	1350	1600	2000	2500	3000	4000	5000	
	THD>33%	-	-	630	800	800	1000	1350	1600	2000	2500	3000	4000	

I-LINE II Copper Contact Busway

Characteristics of straight lengths

General characteristics	Symbol	Unit	Busbar trunking rating(A)									
			800	1000	1250	1350	1600	2000	2500	3200	4000	5000
Compliance with standards			IEC/EN 61439-6									
Protection degree	IP		40~66									
Rated insulation voltage	Ui	V	1000									
Rated operating voltage	Ue	V	1000									
Operating frequency	f	Hz	50/60									

Short-circuit current withstand

	Symbol	Unit	800	1000	1250	1350	1600	2000	2500	3200	4000	5000
Allowable rated short-time withstand current(t=1s)	I _{cw}	kA	40	50	50	50	65	65	90	100	120	150
Allowable rated peak current	I _{pk}	kA	84	105	105	105	143	143	198	220	264	330

Conductor characteristics

Phase conductors			800	1000	1250	1350	1600	2000	2500	3200	4000	5000
Average resistance at an ambient temperature of 20°C	R20	mΩ/m	0.071	0.057	0.043	0.038	0.032	0.025	0.021	0.016	0.012	0.010
Average resistance at Inc	R1	mΩ/m	0.073	0.063	0.054	0.047	0.035	0.033	0.029	0.020	0.016	0.012
Average reactance at Inc and at 50Hz	X1	mΩ/m	0.043	0.042	0.015	0.013	0.024	0.011	0.010	0.008	0.008	0.007
Average impedance at Inc and at 50Hz	Z1	mΩ/m	0.085	0.076	0.06	0.049	0.042	0.035	0.031	0.021	0.018	0.015
Protective conductor(PE)			800	1000	1250	1350	1600	2000	2500	3200	4000	5000
Average resistance at an ambient temperature of 20°C	R	mΩ/m	0.372	0.336	0.24	0.24	0.21	0.23	0.13	0.09	0.08	0.07

Voltage drop

			Line-to-line voltage drop, in volts(V) per metre at 50 Hz with concentrated load. For the case of loads distributed over the run, the voltage drops need times the load distribution factor (see more details in page 86).									
For a cosine φ of	1	V/m	800	1000	1250	1350	1600	2000	2500	3200	4000	5000
	0.95		0.101	0.109	0.117	0.110	0.097	0.114	0.126	0.111	0.111	0.104
	0.9		0.115	0.126	0.121	0.114	0.113	0.120	0.133	0.119	0.123	0.118
	0.85		0.117	0.130	0.119	0.112	0.116	0.119	0.132	0.119	0.124	0.120
	0.8		0.117	0.131	0.116	0.109	0.117	0.117	0.130	0.118	0.123	0.120
	0.8		0.117	0.131	0.113	0.106	0.118	0.114	0.126	0.115	0.122	0.120

Choice of products when harmonics are present (see "harmonic currents" for more details).

Rated current according to THD3(3 rd order distortion)	THD<15%	800	1000	1250	1350	1600	2000	2500	3200	4000	5000
	15%<THD<33%	-	800	1000	1000	1350	1600	2000	2500	3000	4000
	THD>33%	-	-	800	800	1000	1350	1600	2000	2500	3000

I-LINE II

Apart from extreme atmospheres, I-LINE II can be installed anywhere!

The order described below is only aimed at presenting the different stages for a simple installation.

For a detailed design, it is necessary to use appropriate tools, approved by control bodies, in compliance with local installation standards.

Design order:

- 1 - Determining the current rating(Ib).
- 2 - Choosing the busbar trunking rating.
- 3 - Identifying the IPxx protection.
- 4 - Checking the rating with respect to allowable voltage drop.
- 5 - Checking the rating with respect to short-circuit withstand current.
- 6 - Protecting against busbar trunking overloads

1-Determining the current rating(Ib)

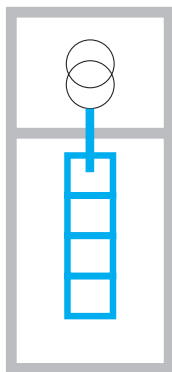

■ Determining by the transformer capacity:

Usc:400/230V					Usc:690/400V				
P(KVA)	In(A)	Usc(%)	Isc(KA)	Ib(A)	P(KVA)	In(A)	Usc(%)	Isc(KA)	Ib(A)
50	72	4	2	100	50	42	4	1	63
100	144	4	4	160	100	84	4	2	100
160	231	4	6	250	160	134	4	3	160
250	361	4	9	400	250	209	4	5	250
400	577	4	14	630	400	335	4	8	400
630	909	4	23	1000	630	527	4	13	630
800	1154	6	19	1250	800	669	6	11	800
1000	1443	6	24	1600	1000	837	6	14	1000
1250	1804	6	30	2000	1250	1046	6	17	1250
1600	2309	6	38	2500	1600	1338	6	22	1350
2000	2886	6	48	3000	2000	1673	6	28	2000
2500	3608	6	60	4000	2500	2091	6	35	2500
3150	4545	6	76	5000	3150	2635	6	44	3200

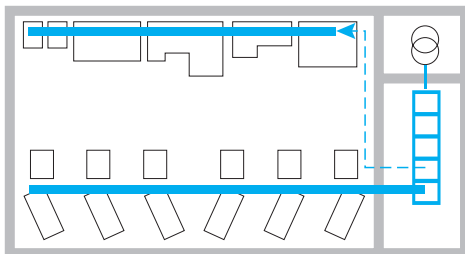

■ Determining by the equipment loads:

Calculation of the total current(Ib) absorbed by a run is equal to the sum of the currents absorbed by all of the loads.

The loads do not all operate at the same time and, as they are not continuously at full load, a stacking or simultaneity factor Ks has to be taken into account:

$$I_b = \sum I_b \text{ load} \times K_s$$

Application	Number of loads	Ks coefficient
Lighting, heating	-	1
Distribution of main circuits	2...3	0.9
	4...5	0.8
	6...9	0.7
	10...40	0.6
	40 and over	0.5

Caution: for industrial installations, remember to take into account future increases in the number of machines. A 20% reserve is recommended.

■ Determining by the floor loads:

Calculation of the total current(Ib) absorbed of one building is equal to the sum of the currents absorbed by all of the load of all floors.

The floors do not all operate at the same time and, as they are not continuously at full loads, a stacking or simultaneity factor Ks and Kf has to be taken into account:

$$I_b \text{ floor} = \sum I_b \text{ load} \times K_s \text{ (as above)}$$

$$I_b = \sum I_b \text{ floor} \times K_f$$

Application	Kf coefficient
Apartments	1
Lighting for commercial using	0.9
Elevators and general service	0.7
conference rooms	0.6
Small office	0.5
Large office	0.4

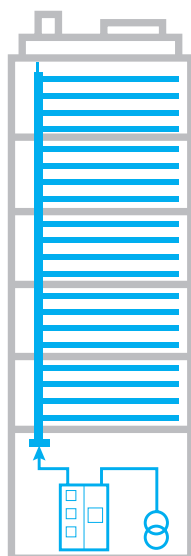

I-LINE II

2-Choosing the busbar trunking rating according to the nominal current In

Nominal current In(A)	Busbar trunking rating
0 to 800	800
801 to 1000	1000
1001 to 1250	1250
1251 to 1350	1350
1351 to 1600	1600
1601 to 2000	2000
2001 to 2500	2500
2501 to 3200	3200
3201 to 4000	4000
4001 to 5000	5000
5001 to 6300	6300

3-Identifying the IPxx protection

1st characteristic numeral: corresponds to protection of equipment against penetration of solid objects and protection of persons against direct contact with live parts.
Protection .

Protection of equipment	Protection of persons		
Non-protected.	Non-protected.	0	
Protected against the penetration of solid objects having a diameter greater than or equal to 50 mm.	Protected against direct contact with the back of the hand(accidental contact).	1	DD210014 Ø 50 mm
Protected against the penetration of solid objects having a diameter greater than or equal to 12.5 mm.	Protected against direct finger contact.	2	DD210531 Ø 12.5 mm
Protected against the penetration of solid objects having a diameter greater than or equal to 2.5 mm.	Protected against direct contact with a 2.5 mm diameter tool.	3	DD210532 Ø 2.5 mm
Protected against the penetration of solid objects having a diameter greater than 1mm.	Protected against direct contact with a 1 mm diameter wire.	4	DD210017 Ø 1 mm
Dust protected (no harmful deposits).	Protected against direct contact with a 1 mm diameter wire.	5	DD210018
Dust tight.	Protected against direct contact with a 1 mm diameter wire.	6	DD210019

2nd characteristic numeral: corresponds to protection of equipment against penetration of water with harmful effects.

Protection of equipment		
Non-protected.	0	
Protected against vertical dripping water(condensation).	1	DD210006
Protected against dripping water at an angle of up to 15°.	2	DD210007
Protected against rain at an angle of up to 60°.	3	DD210008
Protected against splashing water in all directions.	4	DD210009
Protected against water jets in all directions.	5	DD210010
Protected against powerful jets of water and waves.	6	DD210011
Protected against the effects of temporary immersion.	7	DD210012
Protected against the effects of prolonged immersion under specified conditions.	8	DD210013

I-LINE II

4-Checking the rating with respect to allowable voltage drop.

The voltage drop between the start and all points of use must not be greater than the values in the table below :

Installation supplied by:	Lighting	Other use
Low voltage public distribution network	3%	5%
High voltage distribution network	6%	8%

The voltage drop of I-LINE II busbar trunking system with concentrated load can be found in page(80-81).and also can be calculated using the following formular:

$$u = k \times \sqrt{3} \times (R1 \cos\phi + X1 \sin\phi) \times I_b \times L$$

where

- u the composite voltage drop of the system(V)
- R1 and X1 the mean resistance and reactance values of the system(/m)
- I_b the current of the circuit being considered(A)
- L the length of the system being considered(M)
- cosφ the load power factor being considered
- k the load distribution factor

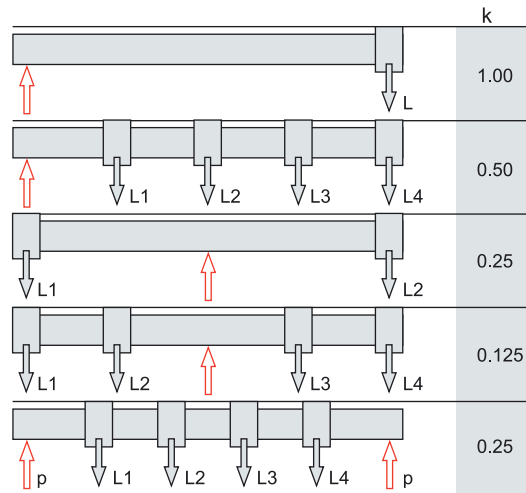

P: Power L,L1,L2,L3,L4: Loads

If the voltage drop exceeds the allowable limits,choose the next rating up.Re-check the voltage drop of the new rating.

5-Checking the rating and choice of circuit breaker with respect to short-circuit withstand current

Short-circuit current withstand is shown in page(880-81).

This value must be greater than the prospective short-circuit current, at all points of the installation.

- Calculate the short-circuit current value at the worst case points.
- Check the chosen rating allows the busbar trunking to cope with this short-circuit current.

If this is not the case, there are 2 possible solutions:

- choose a higher rating busbar trunking and re-check,
- provide a peak current limiting protection system upstream of the busbar trunking.

6-Protecting against busbar trunking overloads.

To allow for extensions, the busbar trunking is generally protected at its nominal current I_{nc} (or its allowable current I_z if the ambient temperature coefficient k_1 is applied).

- Circuit breaker protection:
 - adjust I_r of the circuit breaker such that:
 $I_z = I_b \times k_1 \leq I_r \leq I_{nc}$

Circuit breaker protection allows the I-LINE II busbar trunking to be used at full capacity because the standardised nominal current I_n of the circuit breaker is $I_n \leq I_{nc} / K_2$ where $K_2 = 1$.

- Protection using gG(gL) fuse:
 - determine the standardised nominal current I_n of the fuse such that: $I_n \leq I_{nc} / K_2$
 - where $K_2 = 1.1$.
 - choose the standardised rating I_n that is equal to or just lower.

Check the following condition: $I_n \geq I_b \times k_1 = I_z$.

If this condition is not met, choose the busbar trunking with the next rating up.

Note: using gL fuses for protection means reducing the busbar trunking's allowable current.

I-LINE II

Origin of harmonic current

Harmonic current is caused by non-linear loads connected to distribution systems, i.e. by loads that draw current with a waveform different that that of the voltage that supplies them.

The most common non-linear loads are equipment including rectifiers, fluorescent lighting and computer hardware.

In installations with a distributed neutral, non-linear loads may cause significant overloads in the neutral conductor due to the presence of third-order harmonics.

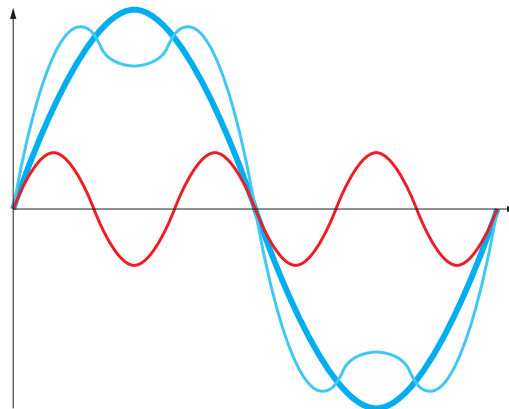

Harmonic order
 The order is the ratio between the harmonic frequency f_n and the fundamental frequency (generally the power frequency, 50 or 60 Hz): $n = f_n / f_1$

By definition, the fundamental f_1 is order 1 (H1).

Third-order harmonics (H3) have a frequency of 150 Hz (when $f_1 = 50$ Hz)

Estimating THD (total harmonic distortion)

The presence of third-order harmonics depends on the applications involved. It is necessary to carry out an in-depth study on each non-linear load to determine the level of H3:

$$ih3(\%) = 100 \times i3 / i1$$

- $i3$ = rms current of H3
- $i1$ = rms current of the fundamental

Assuming that H3 is preponderant among harmonics, the THD is close to the value of H3 ($ih3(\%)$).

There are two decisive factors:

- the types of connected devices:
 - disturbing loads: fluorescent lighting, computer hardware, rectifiers, arc furnaces, etc.,
 - non-disturbing loads: heating, motors, pumps, etc.,
- the ratio between the two types of disturbing loads.



Workshops
 Mix of disturbing loads (computers, UPSs, fluorescent lighting) and non-disturbing loads (motors, pumps, heating).

Low probability of harmonics
THD ≤ 15%.



Offices
 Numerous disturbing loads (computers, UPSs, fluorescent lighting).

High probability of harmonics
15% < THD ≤ 33%.

I-LINE II

Effects of harmonics on I-LINE II busbar trunking

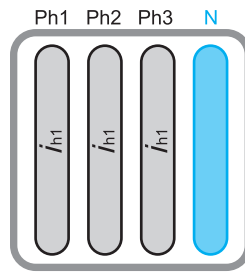

Fundamental frequency: i_{h1} (50 Hz)

No current in the neutral.
The conductors are correctly sized.

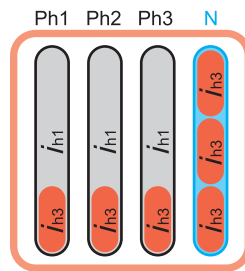

Fundamental frequency: i_{h1} (50 Hz) and 33% of H3

Abnormal temperature rise in the conductors caused by current at a higher frequency in the phases (skin effect) and current in the neutral caused by summing of the H3 harmonics.

The only effective solution

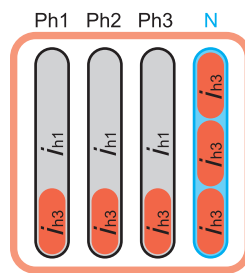

Fundamental frequency: i_{h1} (50 Hz) and 33% H3



Reduce the current density in ALL conductors by using appropriately sized trunking.

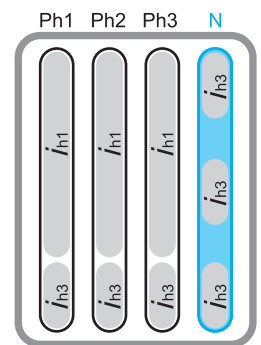

Busbar-trunking selection

THD ≤ 15%	15% < THD ≤ 33%	THD > 33%	Busbar trunking	Rating (A)
630	500	400	I-LINE II	630
800	630	400	I-LINE II	800
1000	800	630	I-LINE II	1000
1350	1000	800	I-LINE II	1350
1600	1350	1000	I-LINE II	1600
2000	1600	1350	I-LINE II	2000
2500	2000	1600	I-LINE II	2500
3200	2500	2000	I-LINE II	3200
4000	3200	2500	I-LINE II	4000
5000	4000	3200	I-LINE II	5000
6300	5000	4000	I-LINE II	6300

Example. For a total rms current of 2356 A, (estimation based on power drawn by loads, including harmonics), the operational current is **2500 A**. THD is estimated at 30%. The appropriate trunking is I-LINE II 3200 A.

For more information on harmonics

See the Cahier Technique publications on the Schneider Electric web site: www.schneider-electric.com

I-LINE II

As required by standards, I-LINE II busbar trunking complies with:

- 1 - material resistance to abnormal temperatures,
- 2 - flame propagation resistance,
- 3 - fire barrier function when going through a partition wall,
- 4 - conservation of all circuits for 0.5-2 hours in a fire resistance sheath.

Definition of tests



1 - Insulating material resistance test to abnormal temperatures

Objective

To check a material will not be suspected as being the origin of a secondary fire outbreak.

As defined in standards § 10.2.3.2 IEC 61439-6 and IEC 60695-2-10 to -2-11.

Method

Application of an incandescent wire for 30 seconds on the insulating materials in contact with live parts.

Result criteria

The specimen is considered to have passed the incandescent wire test if:

- if there is no visible flame and no sustained incandescence,
- the specimen's flames and incandescence go out within 30 seconds of the incandescent wire being removed.

2 - Flame propagation resistance test

Objective

To check a busbar trunking will not create secondary fire outbreaks.

As defined in standards § 10.101 IEC 61439-6 and IEC60332 part 3.

Method

- Application of a flame for 40 minutes on a straight length of busbar trunking whose centre is located 2.5 metres from the edge of the burner.

Result criteria

The specimen is considered to have passed the test if:

- combustion does not occur,
- the maximum extent of the burned part (external and internal) of the busbar trunking does not go beyond 2.5 metres above the lower edge of the burner.



3 - Fire resistance in building penetration



Objective

To check a busbar trunking will not propagate a fire from one room to another by crossing a fire barrier wall for 60, 120, 180, or 240 minutes.

As defined in standard §10.102 IEC 61439-6 and ISO834-1.

Method

The fire barrier busbar trunking section to be tested is placed in an oven which executes a standardised temperature-time curve.

Result criteria

The specimen is considered to have passed the test if:

- there are no flames behind the fire barrier,
- there is no smoke or gas behind the fire barrier (not requested by the standard; can appear as a remark in the test report),
- the temperature rise of the casing behind the fire barrier does not exceed 180°C.

4 - Conservation of all circuits in fire conditions test



Objective

To check all the busbar trunking's electrical circuits are preserved in fire conditions. As defined in standard ISO834-1.

Method

Its entire length inserted, the busbar trunking is taken as a specimen in a fire resistance sheath.

Result criteria

The specimen is considered to have passed the test if:

- conductor continuity is preserved,
- there is no short-circuit between conductors.

I-LINE II

The Transparent Ready concept

Transparent Ready is a simple solution to access information (status, measurements, etc.) available from your electrical distribution equipment (transformers, switchboards, busbar trunking).

This information can be accessed from any PC connected to your Ethernet network via a simple Web browser (e.g. Internet Explorer). No other software is required.

Transparent Ready can make your company more competitive by:

- reducing operating costs
- optimising equipment performance
- improving the reliability of the electrical power supply.

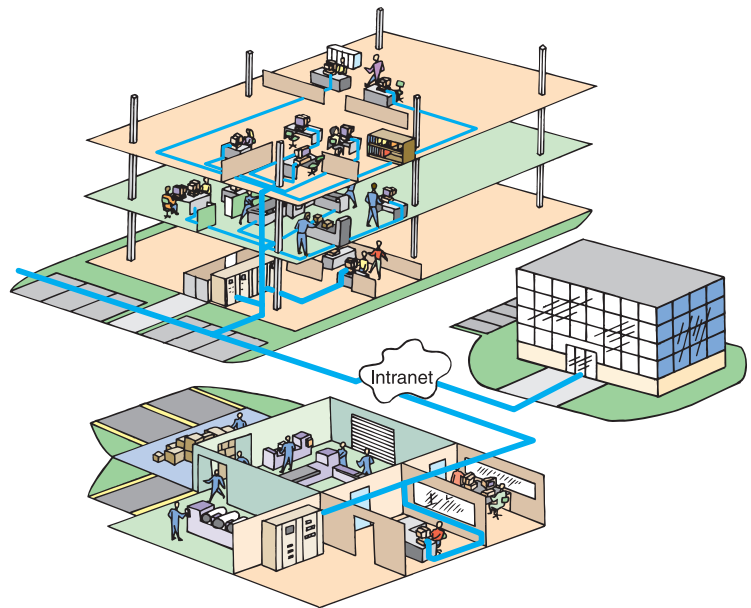
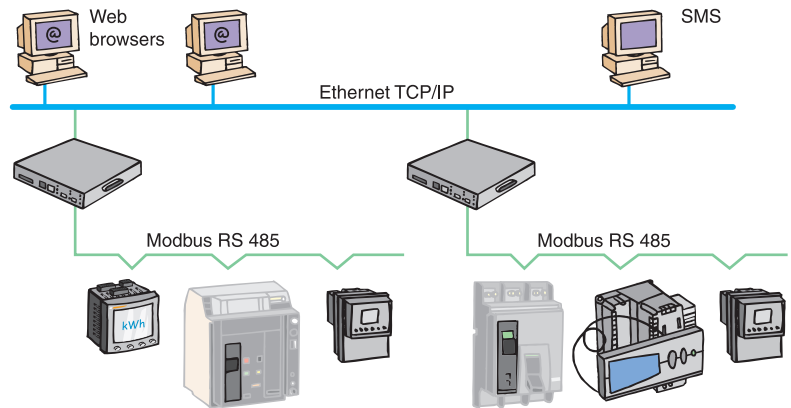
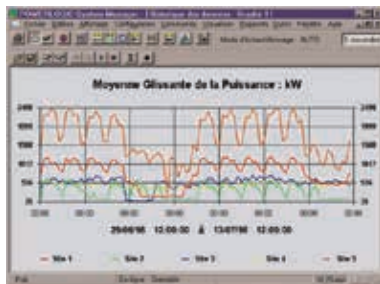

Customer needs for measurements and meterings

In all non-residential buildings, the need for sub-metering exists and is growing under the combined effects of:

- national and supra-national energy regulations,
- the need to reduce overheads and production costs,
- the allocation of energy expenditures to cost centres,
- the outsourcing of operations tasks to specialists.

Operators must therefore have access to reliable pre-processed information in order to:

- identify areas for potential savings,
- model building energy flows and anticipate evolving needs,
- optimise energy supply and consumption.

Measurement and Metering Energy Management System

I-LINE II

I-line II and Energy Management System



I-LINE II offers measurement and metering units. Energy management system is a power monitoring system, it combines NSX MCCB with Micrologic energy measurement, together with BSCM module, IFM and Modbus to realize remote energy measurement, monitoring and data collection/analysis/presentation.

- Monitoring & recording the power consumption, **current, voltage, power, power, quality...**
- **Real time** power data update every 15 seconds
- Detailed **breakdown report** with graph for specified zone
- Power **failure & maintenance** history record



Customer benefits for measurements and meterings

- **Green building strategies**
Optimize investment strategy, shorten payback period
Meet government requirements, gain access to subsidies for green building
- **Expand the market influence**
Stand out with Green brand value, attract more high-end customers
- **Enhance value, reduce operating costs**
Create a Green landmark
Minimize operating costs through energy efficiency
- **Reflect the social responsibility**

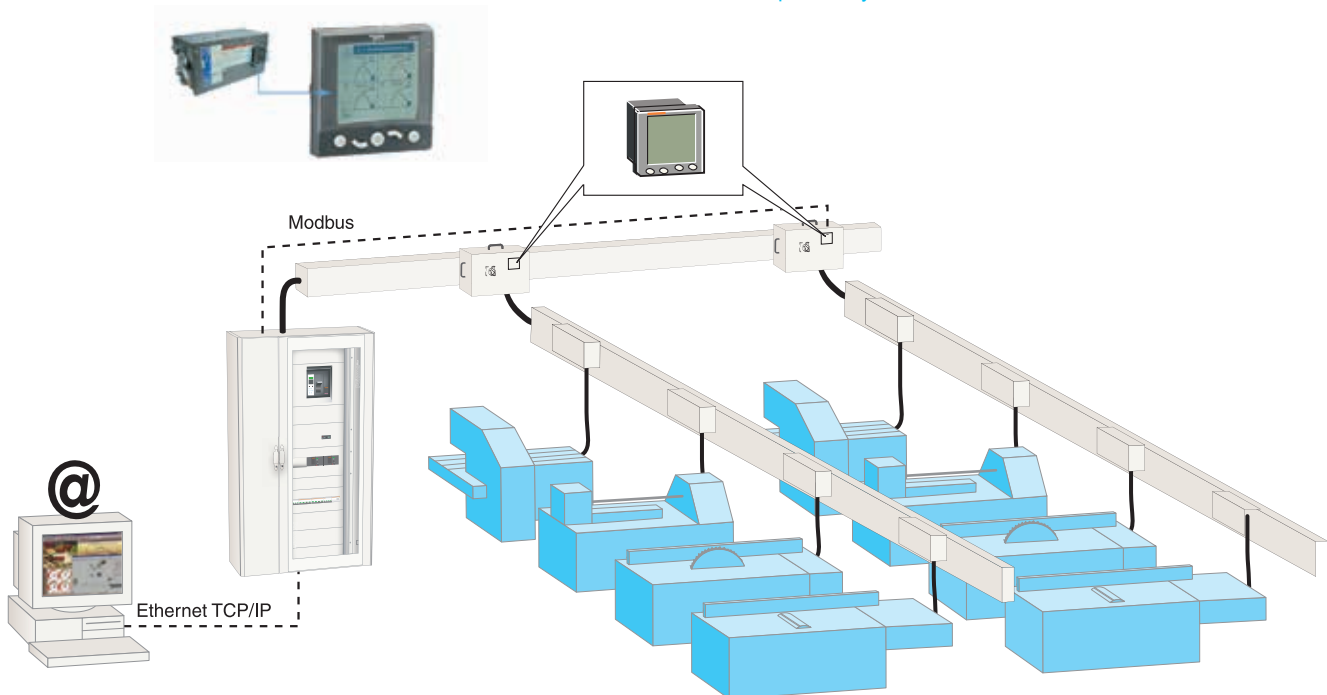

iBusway Solution

Canalis KBA and KBB,25A and 40A for Lighting Management

Power+Control Solution

One integrated lighting busway solution with both power and control, offered by Schneider Electric, delivered as part of an Integrated building management system, is a key tool in controlling energy use inside your buildings. And its partners meet the needs of building users and owners by: reducing installation and operating cost, providing greater flexibility in the use of building space, helping building owners meet legal and building performance regulations. This is our commitment to help individuals and organizations "Make the most of your energy"™



Schneider Electric DALIcontrol is a recommended digital lighting system, which can be synergized with Canalis Lighting busway, creating an enhanced lighting solution.

- Acronym for "Digital Addressable Lighting Interface"
- International Standard (IEC 62386) digital lighting control system.
- Governed by DALI Activity Group, DALI-AG.

iBusway Solution

Canalis KBA and KBB, 25A and 40A for Lighting Management

Schneider Busway remote-control offer

- Factory mounted, a remote-control circuit is available for the loads supplied by the KBA trunking. The main applications are:
- Remote control (rest mode or testing) of self-contained emergency lighting units
 - Dimmer control
 - Recommendation: DALIcontrol
 - Transmission on a building automation bus
 - The system is built in compliance with IEC 61439-6 and the LV and EMC directives
 - The remote-control circuit is factory mounted in the trunking
 - Electrical jointing unit equipped with control bus contacts. Installation of components requires no additional assembly operations
 - Each tap-off outlet is equipped with dual output contacts to tap-off the remote-control circuit to the receiver

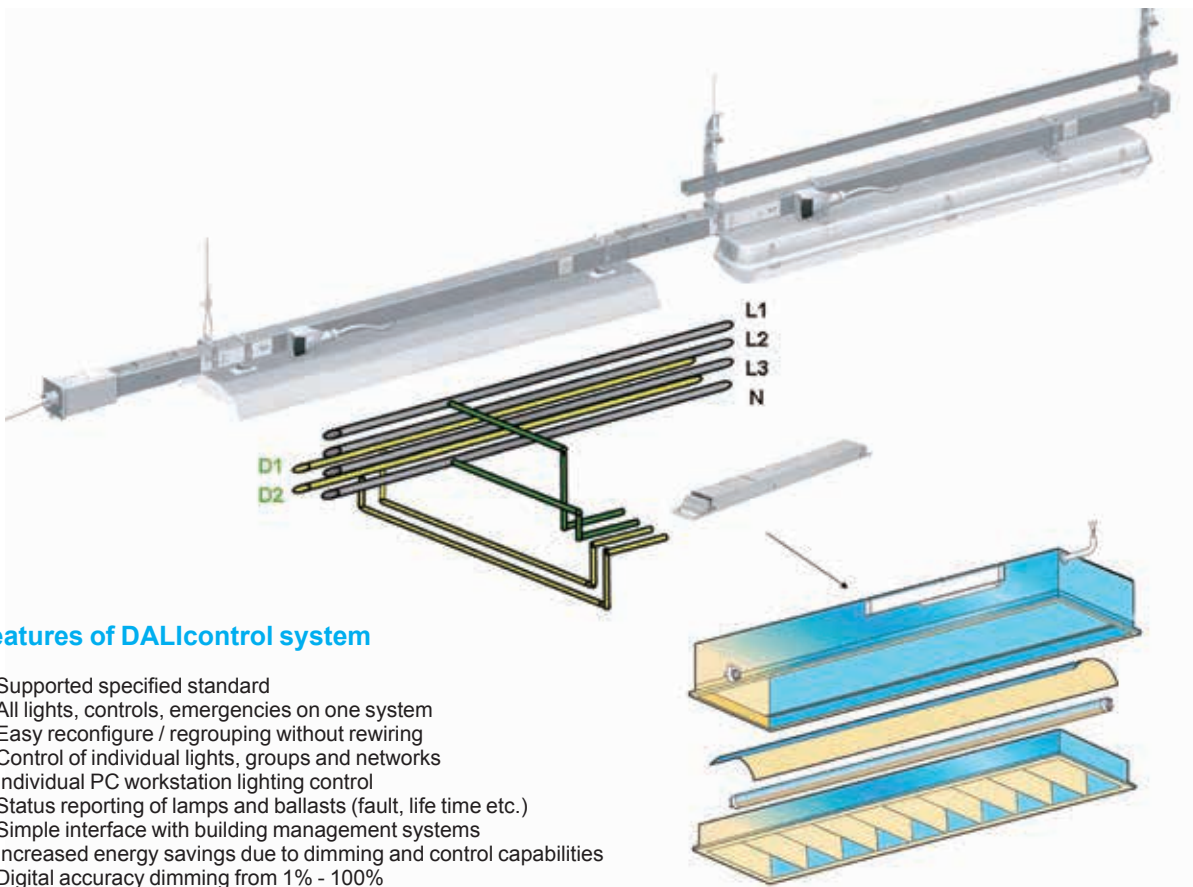

Features of DALIcontrol system

- Supported specified standard
- All lights, controls, emergencies on one system
- Easy reconfigure / regrouping without rewiring
- Control of individual lights, groups and networks
- Individual PC workstation lighting control
- Status reporting of lamps and ballasts (fault, life time etc.)
- Simple interface with building management systems
- Increased energy savings due to dimming and control capabilities
- Digital accuracy dimming from 1% - 100%
- Logarithmic dimming – matching the eye's sensitivity
- Integration of emergency lighting

Environmental efficiency metrics

Application of building performance standards and energy certificates

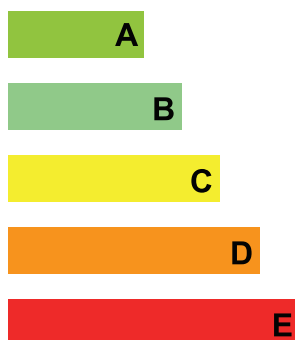

System approach

- New system (incl. Controls)
- New luminaries
- New lamps, new gear
- New lamps



iBusway Solution

Canalis KS, 100A to 800A for Data Center

Schneider Electric iBusway is the solution based on a monitored busway system that combines high availability and energy efficiency.

With the “best in class” Schneider Electric products, we offer Power distribution to the power load

- Canalis KS (straight length & feed unit)
- Canalis KS tap off unit
- MCB M9, Vigi, Auxiliary
- MCCB Compact NSX
- Integration of emergency lighting



Measure to the rack Power distribution to power load

- Energy meter (EN40, PM9-P)
- AS-interface devices (4i Module, bus...)
- Twido PLC
- Micrologic (Compact NSX) & connection

Room supervision

- M340 PLC
- HMI Magelis
- Monitoring application

iBusway Solution

Canalis KS, 100A to 800A for Data Center

Schneider Electric iBusway is the key component for high availability power distribution to server racks in data center. Thanks to prefabricated concept from Canalis KS busway, with tap-off units, monitoring devices and a professional specific control system, iBusway is a "plug & play" solution for quick installation or upgrading for an existing IT facility.

iBusway power distribution solution

- Main distribution: Supplying IT room (critical load) and non-critical load with high power busway
- Major trunking distribution: Power distribution from UPS to secondary switchboard with high power busway
- Terminal distribution: Power distribution from UPS/ Secondary switchboard to each rack with medium power busway

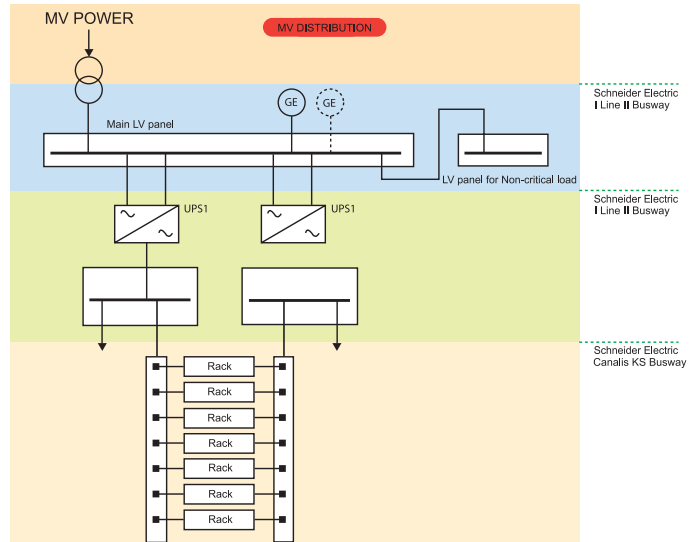

Advantages of power distribution

- NSX circuit-breaker provides full protection between I-Line II and the Canalis KS
- Full redundancy solution with two separate Canalis KS
- Each rack is supplied by two tap-off units from different Canalis KS
- Measuring and monitoring functions are optional to be integrated with PMS

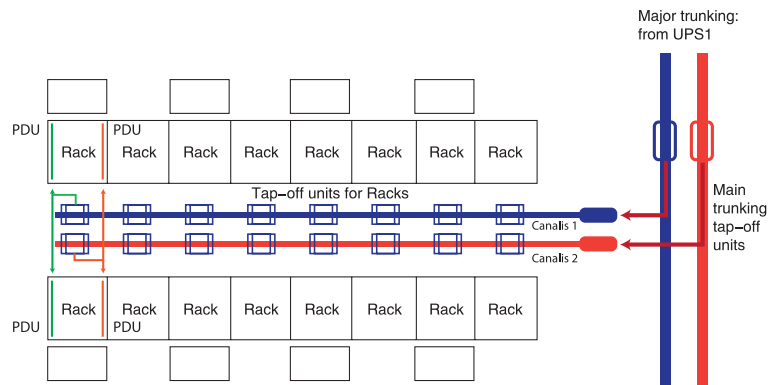

iBusway monitoring solution

- Terminal monitoring: tap-off units with EN40, PM9 and communication module
- Major trunking monitoring: tap-off units with NSX circuit breaker
- Human machine interfaces: system with TWIDO, M340 and HMI Magelis

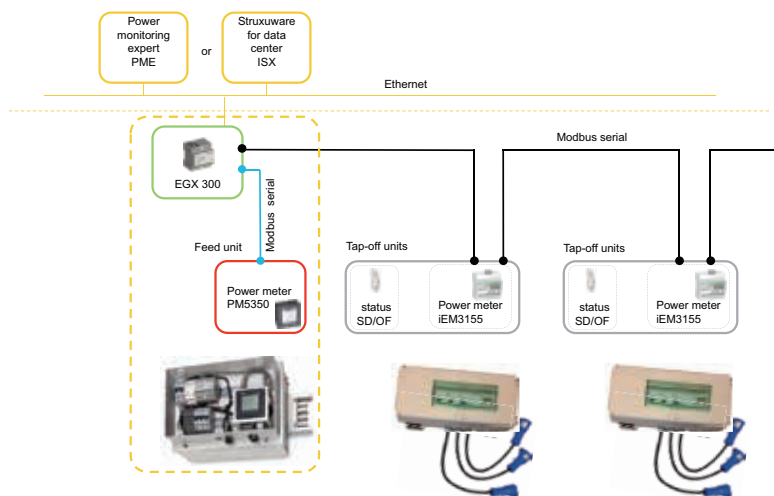

General advantages

- Real time energy monitoring
- Real time monitoring and failure warning for every rack
- Real time power quality monitoring: load factor, harmonic
- Real time power parameter communication
- Open bus system and protocol

I-LINE II

Determining the DC current value

Thermal effect

Rule

The total power dissipated as heat must remain constant in the duct: $P_{ac} = P_{dc}$

Where:

- the power dissipated as heat: $P_{ac} = 3 \times R \times I_{ac}^2$ where:
 - R = resistance of a conductor,
 - I_{ac} = conductor rms current,
- the dissipated power for 4 conductors: $P_{dc} = 4 \times R \times I_{dc}^2$ where:
 - I_{dc} = direct current.

Selection table

■ 1 source

Case of 2 conductors in parallel for the + and 2 conductor in parallel for the - (only 1 circuit in the busbar trunking):

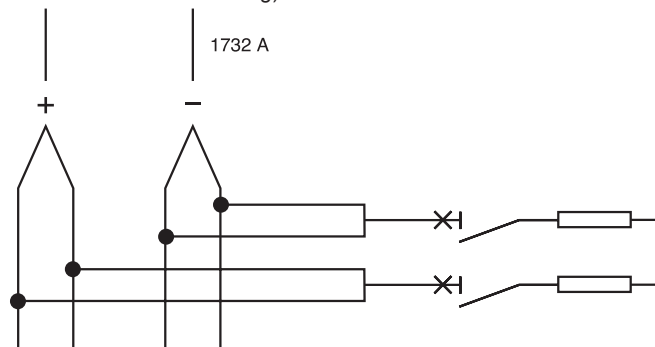

■ 2 sources

Case of 1 conductor for the + and 1 conductor for the - (2 circuits possible in the same busbar trunking):

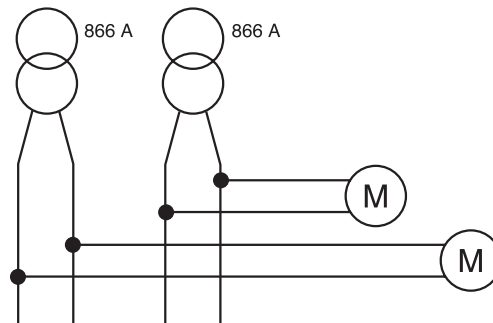

Busbar trunking rating(A)	1 source	2 sources
630	1091	546
800	1386	693
1000	1732	866
1250	2165	1082
1350	2338	1169
1600	2771	1385
2000	3464	1732
2500	4330	2165
3200	5542	2771
4000	6928	3464
5000	8660	4330
6300	10911	5456

Installation Guide

Layout Advice	98
Rising Main	101
Reception, Handling and Storage	103
Testing and Commissioning	105
Maintenance	109

Layout Advice

Position and Support

I-LINE II

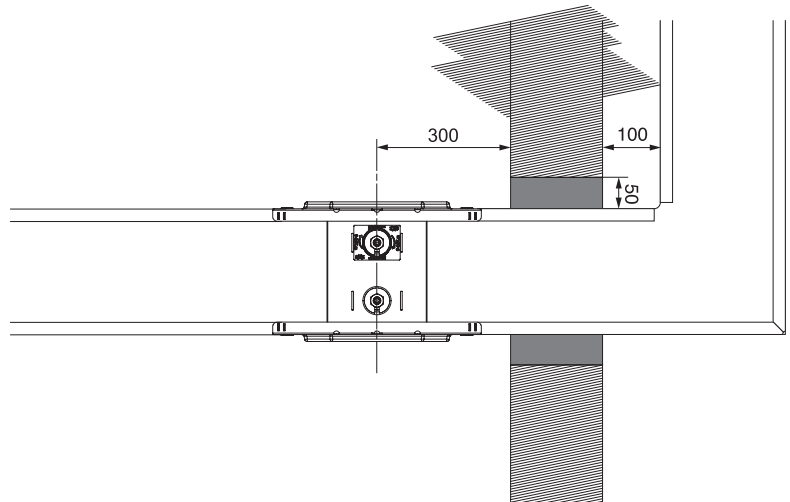

Edgewise passage through wall

Flatwise passage through wall

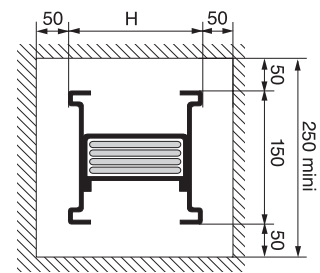
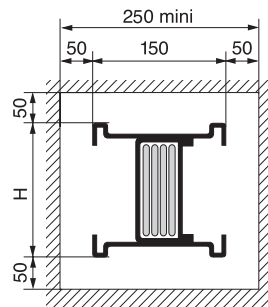

H: the width of I-LINE II busway in Page

Layout Advice

Position and Support

I-LINE II

A support point as close as possible to the connections is needed because transformers, generator sets and switchboards must not support the weight of the busbar trunking. In some industries, for service continuity reasons, transformers may be replaced quickly. The busbar trunking must be able to support itself.

Edgewise horizontal installation

The maximum recommended distance between supports is 3 metres.

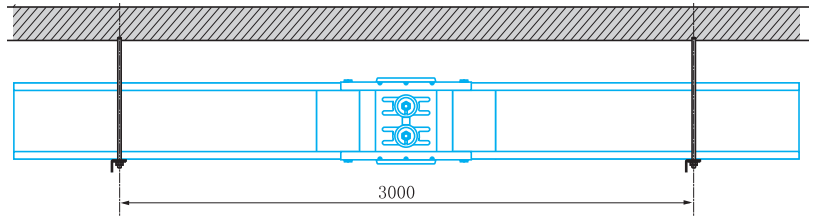

Flatwise horizontal installation

The recommended distance between supports is 2 metres. In addition, a support must be placed at 3000 mm from the center of joint pak.

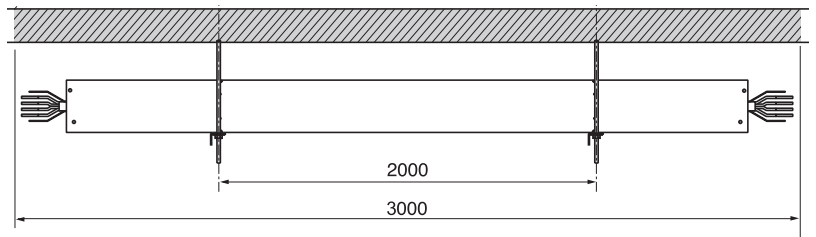

Example of spreading out supports

Plan for a maximum distance between supports of 3 metres.

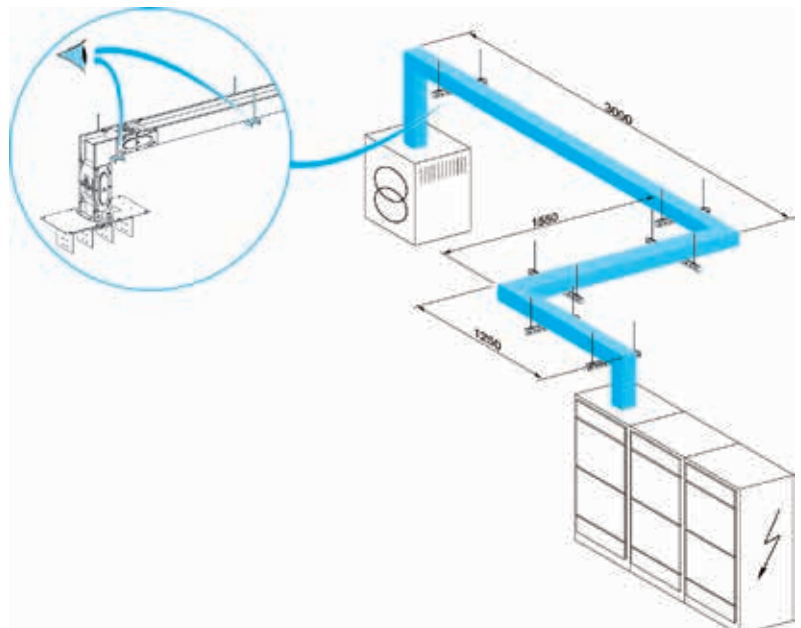

Layout Advice

Position and Support

I-LINE II

Defining the layout, dimensions to be provided

The position of the joint block with respect to the transformer axes and switchboard edges (defined in the "Installation guide").

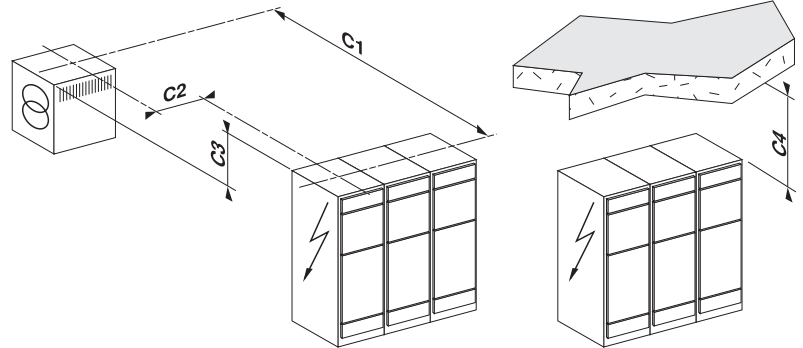

Distance of the busbar trunking from the wall

Edgewise installation

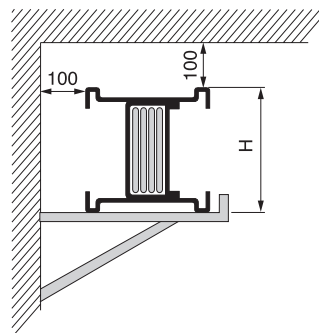

Flatwise installation

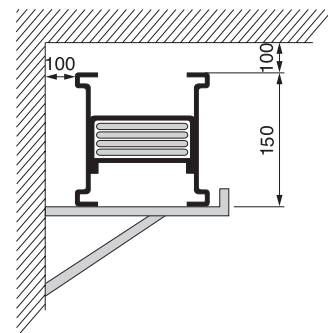

H: the width of I-LINE II busway in page

Distance between busbar trunking (without plug-in units)

Edgewise installation

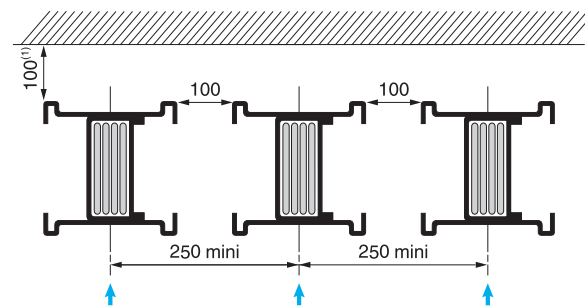

(1) Provide 2 times the height if the joint block must be fitted from the top.
 → Direction of fitting joint blocks.

Flatwise installation

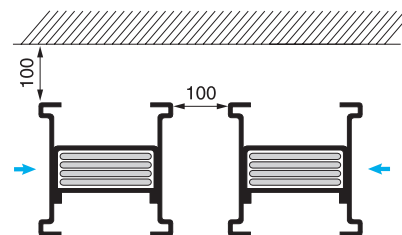

→ Direction of fitting joint blocks.

I-LINE II

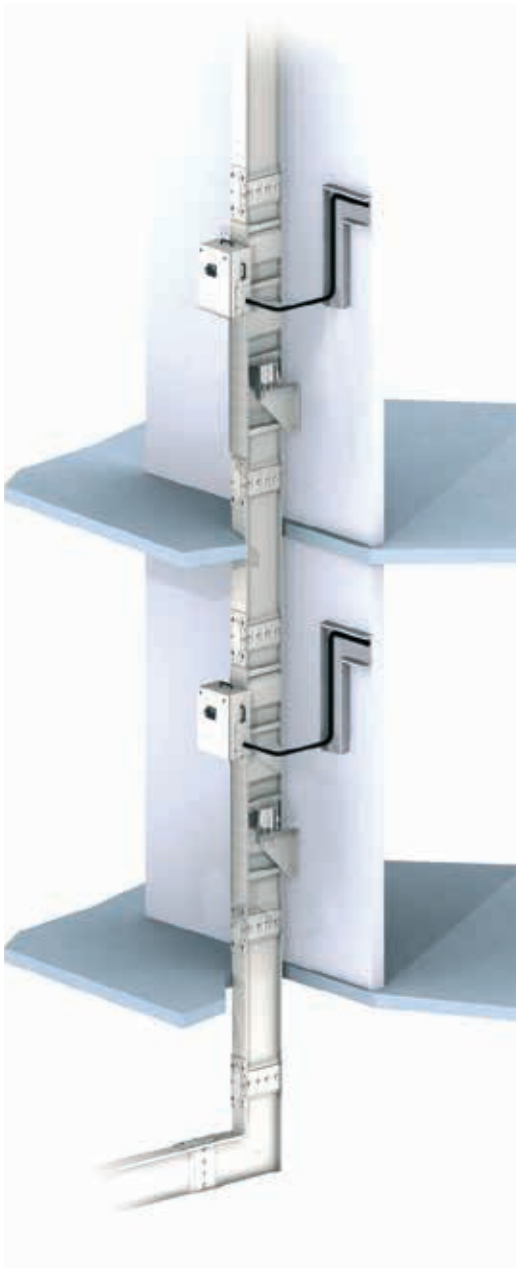

I-LINE II enables power distribution to each floor of multi-storey buildings (office buildings, hotels, hospitals, etc.). In this application, I-LINE II retains all its construction principles:

Installing a rising main

1 Installation principle

Installation at each floor of:

- a 4 or 6 feet riser section,
- a made to measure transport section to go through the floor slab,
- a busbar trunking support.

2 Installation feed

The installation feed is achieved using either a cable end box or by a flanged end connection to an electrical distribution switchboard.

3 Busbar trunking supports

The supports fix the vertical run section to the building structure – a floor slab support. It can be fixed to either the wall, to a wall bracket or directly to the floor.

This type of fixing support has the following advantages:

- fitting to either the wall, to a wall bracket or directly to the floor,
- spring adjustment to ensure distribution of the load at each floor,
- absorption of building stresses with respect to the busbar trunking (expansion, vibration, etc) thanks to the springs.

4 Plug-in units

All I-LINE II plug-in units can be mounted vertically.

I-LINE II

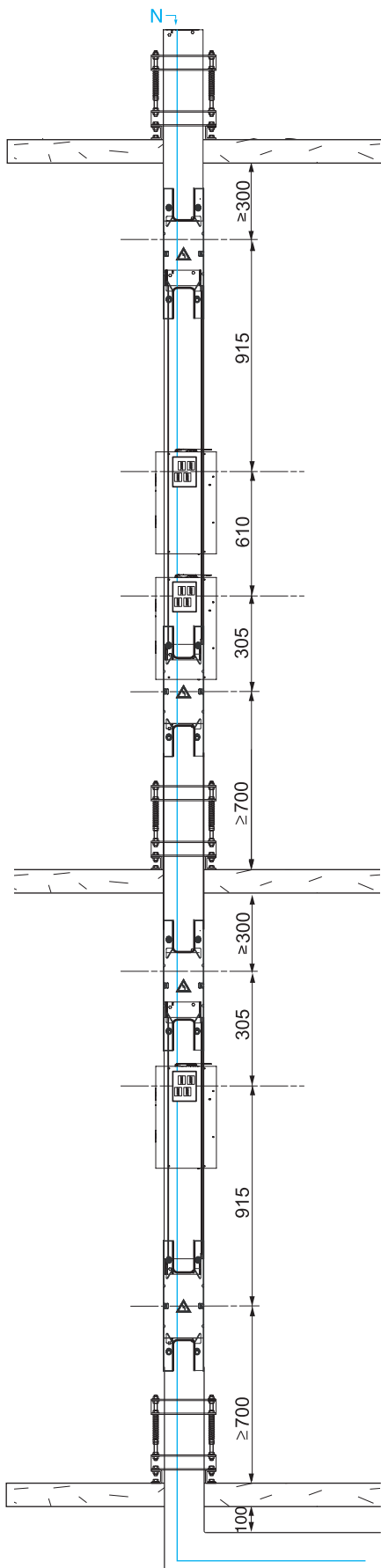

Positioning the neutral

The busbar trunking must be positioned with the neutral on the left when facing to the busway and plug-in units.

Positioning the joint

It is important the joint block is not positioned in the floor slab or in spring hanger.

We recommend you provide for a distance of:

- 700 mm between the floor and the joint block axis to be able to install the spring hanger (considering 100mm curb).
- 300 mm between the upper joint block and the ceiling to allow the busbar trunking to be boxed-in.

Positioning the plug-in units

The riser sections are fitted with 1/2/3 plug-in openings in 4/6/10 feet.

Remark

Please refer plug-in openings quantity and position in page 38. If more than one plug-in unit used in the same floor, please consider the PIO position and PIU dimension in case of interference.

Positioning the multi runs

Positioning the multi runs according to the interval requirement of the plug-in units.

The recommended dimension is as below:

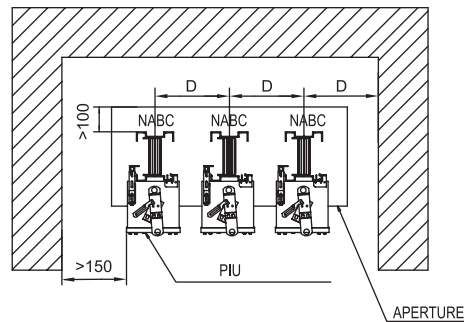

PIU Trip Rating	D (Minimum distance)	D (Assemble randomly)
<250A	250	300
400A~500A	400	450
>630A	500	500

I-LINE II

This document contains practical information, lays out the general recommendations (as a complement to the installation regulations) and specifies the basic instructions that must be respected when handling and storing Schneider Electric I-LINE II busbar trunking system.

The purchaser's engineering, installation and operating staff must become acquainted with this document and become familiar with the appearance and characteristics of each of the I-LINE II busbar trunking system's components. Appropriate planning and coordination between the different job functions is indispensable for ensuring an efficient installation of the equipment.

Each I-LINE II busbar trunking system is carefully inspected and packaged at the assembly plant.
The entire system is checked both structurally and electrically.
At the end of inspection, the busbar trunking system is prepared for shipping.
Each section is packed to guarantee easy handling before its installation.
The catalogue number is written on each shipping unit.

Warning

RISK OF ELECTRIC SHOCK, BURNS OR EXPLOSION

- Protect the equipment against all contact with water, salt, concrete and other corrosive surroundings both before and during installation.
- Outdoor equipment is not resistant to bad weather until after it has been fully and correctly installed.
- Do not sit or walk on the equipment.

If these instructions are not respected, the equipment may deteriorate leading to a risk of serious or mortal injury.

Reception

Upon reception, check the information on the shipping note corresponds to the equipment received to ensure all of the order has been received and shipped. Complaints concerning missing components or other errors must be sent in writing to Schneider Electric within 30 days from the date the shipping item was received. If no complaint has been received within 30 days from the date the shipping item was received, Schneider Electric will no longer be responsible for repairs or replacements that may be required.

Upon reception, check the various units of the busbar trunking system immediately to identify any damage that has occurred during transport. If there is observed or suspected damage, file a claim immediately with the carrier and inform the nearest Schneider Electric office.

Handling

Handle I-LINE II products with the greatest of care to avoid damaging the internal components of the system and to avoid changing the external appearance of the various parts, as well as the bar ends (connection terminals).

The busbar trunking must be constantly supported by independent means, in such a way its weight is not resting on the top of the transformers or distribution switchboards.
The distance between these support means must not exceed 3 metres.

Avoid exposing the busbar trunking to twisting, embossing or impacts, and all other actions likely to causing damage.

Ensure the handling equipment available at the site of installation is suitable for handling busbar trunking. In particular, check the lifting capacity of the crane or the other lifting equipment to be used.

I-LINE II

Take great care when unpacking the equipment:

- use a nail-head puller when unpacking wooden crates,
- if hauling the busbar trunking with a crane, use Nylon slings to spread the weight of the unit being lifted,
- if using cables, insert a spacing means to avoid damaging the busbar trunking,
- if using a forklift truck, position the busbar trunking on the forks in such a way the weight is evenly distributed.

1 - Cut the strapping holding the packaging case using suitable cutting tools.

2 - Use suitable tools to remove the strengthened steel packaging at each end of the busbar trunking.

Take care not to damage the steel box so as not to damage the busbar trunking. Avoid the use of objects with sharp edges when lifting the busbar trunking.

3 - Dispose of all used packaging in an appropriate way.

Never drag the busbar trunking along the floor. Do not use the end bars to lift sections of the busbar trunking.

Protection against humidity during storage

If the busbar trunking is not installed and commissioned immediately, leave it in the original I-LINE II packaging and store it in a clean and dry place at a uniform temperature.

The busbar trunking must not be stored outside. However, if outside storage is necessary, cover the busbar trunking in such a way as to protect it from bad weather and to avoid contact with the elements.

Temporary electrical heating must be provided for underneath the covering means to prevent condensation. The supplied heat must be of suitable temperature and uniformly distributed underneath the covering means.

Outdoor busbar trunking is not resistant to bad weather until after it has been fully and correctly installed. During installation, take particular care to protect rising mains from humidity arising from unfinished roofs, walls and other similar elements.

All the operations described below are given for indication only. Under no circumstances can they be used to substitute the installation company's own procedures and engage Schneider Electric's responsibility.

Scope

High power busbar trunking, transformer-switchboard links.

Required tools

- multimeter,
- 500V megger,
- roto-phase.

Prerequisites

- If need be, the old equipment has been removed from the premises.
- The new equipment has been manoeuvred into the premises where it is to be installed by the installation contractor.
- The equipment has been installed by the installation contractor in accordance with manufacturer's recommendations.
- The equipment's installation diagram, connection diagram and assembly results sheet are available for the commissioning engineer.

De-energising the installation and making it safe

The works manager is responsible for worksite safety and must ensure the installation is de-energised and made safe in accordance with safety rules before any inspection or measurement is performed.

After the installation contractor has positioned, assembled and connected the busbar trunking in accordance with the supplied installation, assembly and connection diagrams, and using the recommended tools and handling equipment, the following characteristics must:

- be noted,
- be checked for compliance with respect to the details shown on the drawing.

Equipment checking, positioning and identification

Brand	-	Busbar trunking rating:	-
Equipment type:	-	Serial number:	-
Reference:	-	Date of manufacture:	-
Transformer power:	-	Source circuit breaker (busbar trunking protection):	-

General visual inspection

The equipment has been chosen according to its electrical environment (rating and protection adapted to operating conditions).

The following points do not require checking.

Points concerning reception, storage and handling

No signs of:

- shock (which may deteriorate internal insulation: conductor insulation on straight lengths or at the tap-off points or joint blocks),
- humidity or oxidation (equipment stored outside should have been covered with a plastic sheet, sheltered from humidity, dirt and dust),
- firm's label defining the product's characteristics.

I-LINE II

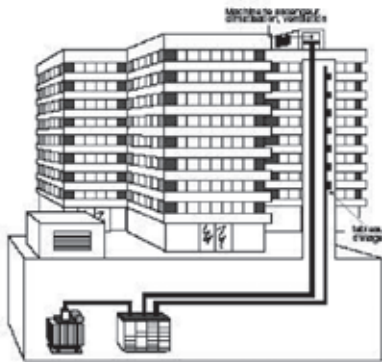

Points concerning installation and fittings

Assembly compliance with the specifications of the installation drawing, service instructions and the catalogue:

- no busbar trunking twisting,
- positioning and distance of the busbar trunking with respect to the building,
- fixings, compliance of the between centres distance of the equipment for flat or edgewise, horizontal or vertical distribution,
- clamps, not fully blocked to allow movement due to longitudinal forces ,
- presence of expansion sections if necessary.

General visual inspection

Check the number of connection parts and their cross-sections for each conductor (see "Installation guide").

Check insulation distances between 2 conductors and between conductors and metal panels.

Check the tightening torque of bolts not fitted with torque nuts. For bolts fitted with torque nuts, check the head has broken-off.

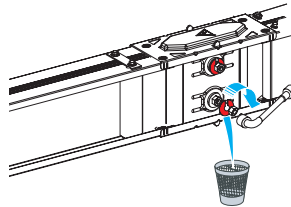

Check the bolt length exceeding the nut (10 mm); some bolts may have been removed and then put back, but left untightened.

Mark each tightened nut using indelible varnish. As well as a means of self-inspection to ensure correct tightening torque, it also allows any untightening to be identified.

Class 8-8 nuts and bolts (M8 on LV switchboard side, see "Commissioning Guide for Schneider Electric LV Switchboards").

Bolt	Tightening torque
HM16	16 mdaN
HM14	12 mdaN
HM12	7 mdaN
HM10	5 mdaN

Checking power connections

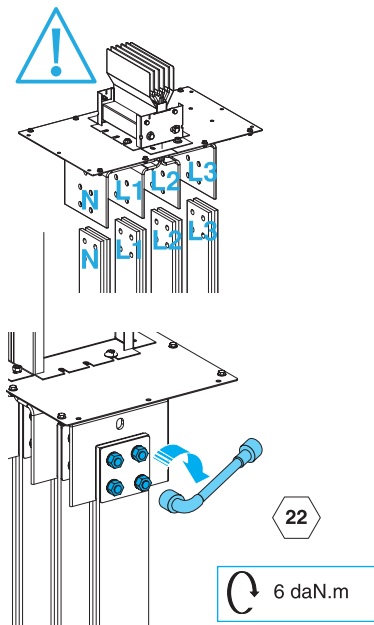

The results of all these checks must be noted on the results sheet by the installation contractor.

Checking insulation between live conductors

These measurements and checks can only be performed if:

- each link is disconnected by an isolating device,
- each link is disconnected from the upstream transformer, with the main circuit breaker upstream of the LV switchboard unplugged and in the open position.

Test means: 500V DC megger (DC to avoid capacitive currents)

Measurements: 6 measurements between live conductors (between phases and then between each phase and neutral).

LV circuit insulation value (U < 500 Volts): 1000 ohms/volt of nominal voltage (IEC 61439-6) allowed.

In all cases, the insulation resistance must not be less than 0.5 MΩ for each link (operating device).

Note: I-LINE II busbar trunking is given for U = 1000V and Ri = 1 MΩ (value to be taken into account for all elements: transport and accessories, distribution).

I-LINE II

Checking the earth network and locks



Earth network

General visual inspection

Check:

- the galvanised steel casing sides are earthed (note: this depends on the earthing system),
- connection quality,
- cable cross-section,
- there are no loose metal parts (washers, screws) in the plug-in units.

Note: the results of these checks must have already been noted on the results sheet by the installation contractor.

Checking insulation between live conductors and earth

Following this check, each link must be reconnected to the upstream transformer (use the 2nd available 6 daN.m torque bolt heads).

Test means: 500V DC megger (DC to avoid capacitive currents)

Measurements: between each phase or neutral⁽¹⁾ and earth (the casing if it is connected to earth).

LV circuit insulation value ($U < 500\text{ V}$): 1000 Ω of nominal voltage (IEC 61439-6) allowed.

In all cases, the insulation resistance must not be less than 0.5 M Ω for each link (operating device).

Note: I-LINE II busbar trunking is given for $U = 1000\text{ V}$ and $R_i = 1\text{ M}\Omega$ (value to be taken into account for all elements: transport and accessories, distribution).

(1) No neutral insulation if the earthing system is such that the neutral is connected to or used as the earth.

Caution: In this case, once the transformer has been reconnected (star secondary), the phase-earth measurement is the winding resistance.

PE protective circuit equipotential

Reference: IEC 61439-6:

Check PE protective circuit continuity by visual inspection and random continuity testing.

The previously performed "phases-PE" insulation test must have been compliant.

Test means: ohmmeter.

Locks

To protect personnel by not allowing access to live parts through the use of locks. Only concerns key operated safety locks.

STEPS TO TAKE BEFORE ENERGIZING

Before energizing the busway, conduct an insulation resistance test on the busway run. The megohm readings should not be less than the value calculated from the following formula, neither less than 5 Megohms. (If not, please contact your local Schneider Electric office.)

Megohms=100/length of run (in feet) or Megohms=30.5/length of run (in meters)

Check not relevant to busbar trunking.

Checking connections and auxiliary testing

I-LINE II

De-energised equipment operating tests

Checking source circuit breaker protection settings

Compliance check in accordance with the installation drawing specifications:

- I_{max} thermal,
- I_n magnetic.

Note: this check is only to be performed if the busbar trunking is commissioned at the same time as the transformer: the source circuit breaker protection setting checks are related to transformer commissioning.

Check not relevant if the transformer has already been commissioned.

If this check is successful, the busbar trunking can be commissioned and the energised operating tests performed with the appropriate protective equipment

Commissioning and energised equipment operating tests

NOTE: commissioning can only be carried out by personnel with appropriate authorisations.

Preliminary operation: energising the off-load transformer.

Closing the source circuit breaker.

Checking phase order

Objective: to detect, in order to correct, an inversion of the phases or neutral amongst the busbar trunking's 4 incoming and outgoing connections with respect to the transformer output.

Test means: roto-phase or 3-phase harmonic analyser.

If busbar trunking energising is successful, a progressive start-up of the factory must be requested to definitively validate commissioning.

If unsuccessful, the previous checks must be carried out again to try and locate the fault. Before undertaking this, the equipment must once again be made safe.

Final putting into service test

This test is performed once the busbar trunking has been energised. The progressive start-up of loads will highlight any undesirable phenomena due to the increased average load.

Real life operating test

Once the high power busbar trunking has been energised, the other busbar trunking must be gradually put into service starting with those furthest from the load, then each load itself, those with high pull-in currents, then the lighting, contactors, heating, motors, etc.

There must not be excessive vibration, and no sparkovers should be observed.

The test simply consists of checking correct busbar trunking operation according to:

- the average number of machines in operation,
- the load variation of each individual load,
- the simultaneous operation of machines (superimposing of peaks).

If everything is in order, the busbar trunking is declared "in-service". Testing is completed.

I-LINE II

Danger

RISK OF ELECTRIC SHOCK, BURNS OR EXPLOSION

The installation, operation and maintenance of the equipment must only be carried out by qualified electrical maintenance staff. This document must not be considered as being a sufficient means for allowing non-qualified staff to undertake the operation and maintenance of the equipment.

- Cut the electrical supply to the busbar trunking before installing, removing or working on the equipment.
- Always use a suitable nominal voltage detection means to confirm the supply has been cut.
- Effective use of the equipment requires the implementation of appropriate handling, installation, functioning and maintenance operations.

If these instructions are not respected, there is a risk of serious injury or death.

Warning

RISK OF DAMAGING THE EQUIPMENT

Hydrocarbon aerosols and aerosols using a hydrocarbon base may cause the deterioration of certain plastics.
Before using certain products to clean, dry or lubricate the different components during installation or maintenance, consult your nearest Schneider Electric office.

If these instructions are not respected, the equipment may deteriorate leading to a risk of serious injury or death.

Straight length

I-line II busbar trunking has been designed for minimum maintenance. Inspect the busbar trunking once a year, or after all serious incidents concerning electrical short-circuits or earthing faults.

Carry out the following maintenance procedures:

- meticulously inspect all visible electrical connections and joints. Do not remove joint covers. Check the nuts and bolts are correctly tightened,
- use a torque wrench to check bolt tightening torques.

The tightening torque is marked on the connection block and the following values must be respected:

Bolt	Tightening torque
HM 16	16 mdaN
HM 14	12 mdaN
HM 12	7 mdaN
HM 10	5 mdaN

If one of the joints or terminals is highly discoloured, corroded or pitted, or shows signs it has been exposed to high temperatures, the material concerned must be replaced with new factory mounted material. Consult your local Schneider Electric office for all replacements,

- ensure all mechanisms are in good working order.
- Lubricate the moving parts of the various mechanisms if necessary. Similarly, remove all excess lubrication to avoid undesirable foreign bodies from gathering,
- check the insulation resistance before re-energising the busbar trunking.

It is recommended that resistance measurements are recorded. If these values decrease significantly over time, it means deterioration is underway.

Carry out an insulation resistance test in compliance with the instructions given in the “testing and commissioning procedure” section.

Re-energise the equipment in accordance with the instructions given in the “testing and commissioning procedure” section.

I-LINE II

Distribution plug-in units

After having performed all the necessary inspections and repairs mentioned above, it may be desirable to carry out infrared temperature measurements on all the electrical connections. This operation must be done once the busbar trunking has been re-energised and reached a stabilized temperature.

Responsibility

Schneider Electric declines all responsibility for maintenance carried out in a non-compliant way with respect to specifications or installation regulations, for inappropriate storage conditions, for inappropriate product environments (chemical and ambient conditions, atmospheric conditions, etc.), for the incorrect use of the products, and for the non-respect of installation and/or connection procedures.

Contact between busbar trunking and plug-in units.

Busbar trunking contacts consist of spring silver plated contact jaws to ensure optimum contact quality. The contacts do not use plastic for their support or transmission of force.

They are connected to the live conductors of the run at the plug-in outlets. Silver-plated copper conductors are used at the place of contact.

These devices are maintenance-free.

Cable connection

Cable connection of the feeders are via terminals or lugs.

As with all screw connections, it is recommended that tightening torque be checked one year after installation and then to space-out the checks.

Protection switchgear

For all devices fitted in I-LINE tap-off units, the manufacturer's recommendations must be complied with.

Checking appearance

It is recommended the external cleanliness of the tap-off units be checked yearly to remove dust, water and oil deposits, may affect thermal cooling and all other conductive bodies from the sensitive zones.

Check for signs of shock which may affect the protection degree.

Recycling busbar trunking

I-LINE II busbar trunking can be reused. I-LINE II busbar trunking is designed for a long service life and can easily be dismantled, cleaned and reused.

All packaging materials can be recycled (cardboard or recyclable polyethylene film).

All I-LINE II products are designed for safe end-of-life recycling. PVC, on the other hand, requires neutralisation of the hydrochloric acid produced using lime and generates dioxins that are extremely toxic.

I-LINE II helps conserve natural resources

The depletion of raw materials (copper, plastics, etc.) is one of our ongoing concerns.

For this reason, we have optimised the used of all materials used to make our busbar trunking.

- Reduction of dangerous or polluting materials. We design our products to meet future worldwide directives.
- Reduction in the weight of insulating materials.
- Reduction in the use of plastics for improved fire performance: less energy released during combustion, thereby limiting propagation and facilitating extinction (lower calorific value).



Example:
1 kg of PVC generates 1 kg of waste.

Suggested Specification

Busbar Trunking System

112

Suggested
specifications

A. Manufactures

All busbar trunking shall be I-LINE II busbar trunking manufactured by Schneider Electric.

B. Products

1 General

- 1.1 The busbar trunking system (630A and above), both feeder and plug-in, shall be sandwich construction. All busbar trunking products and fittings (straight length, elbow, tees, flanged ends, cable tap box and circuit breaker, etc.) shall be in accordance with IEC 61439:2012 and from the same manufacturer as the busbar trunking system. The degree of protection of the busbar trunking system should be IP54 in accordance to IEC 60529.
- 1.2 Rated operation voltage of the busbar trunking is 1000V. 3 - Phase, 4 or 5 Wire with 50% capacity continual integral/internal earth busbar. The neutral conductor should have the same cross-sectional area as the phase conductor. The earth busbar must be one continuous piece without bolting on housing
- 1.3 The ampere ratings, approximate footage, fitting, plug-in units etc. are shown on the plan. The electrical contractor shall be responsible for routing the busbar trunking to coordinate with the other trades. Final field measurements shall be made by the contractor prior to release to the busbar trunking for fabrication by the manufacturer.

2 Certificate

- 2.1 The busbar, of full range and each rating, should pass full type tests specified in IEC 61439:2012. The certificate shall be issued by an international independent testing authority (e.g. ASTA, KEMA).
- 2.2 A product safety mark (e.g. KEMA-KEUR, ASTA DIAMOND) should be on the product offering a visible assurance to all of full product safety testing, factory inspection and ongoing surveillance under independent authority to ensure the ongoing safety of product.
- 2.3 The busbar trunking system should pass seismic tests with actual physical product and being certified complying with UBC seismic Zone 4 condition by an international recognized earthquake research body, e.g. Asian Pacific Network of Centers for Earthquake Engineering Research (ANGER).

3 Short Circuit Ratings and Tests

- 3.1 The whole busbar trunking system shall be capable of withstanding the short circuit of the electrical installation without damaging the electrical, mechanical and thermal stress under fault condition at a service voltage of 1000V 50Hz. The minimum rated insulation voltage shall be 1000V.
- 3.2 The minimum certified short circuit ratings of the busbar trunking shall be as follows

Rating	KA/1 sec.	KA Peak	Rating	KA/1 sec.	KA Peak
630A	40	84	2000A	60	132
800A	40	84	2500A	75	165
1000A	45	94.5	3200A	80	176
1250A	50	105	4000A	100	220
1350A	50	105	5000A	120	264
1600A	50	105	6300A	120	264

-
- 4 Housing
 - 4.1 The busbar trunking housing shall be constructed of code gauge steel and aluminum to reduce hysteresis and eddy current losses and shall be provided with a suitable protective finish of ANSI 49 grey epoxy paint.
 - 4.2 The busbar trunking housing shall be totally enclosed non-ventilated for protection against mechanical damage and dust accumulation. And it shall pass at least 500 hours salt spray test to ensure the anticorrosion ability.
 - 4.3 The totally enclosed housing shall be manufactured by the busbar trunking manufacturer. Modifications of busbar trunking to make it totally enclosed by other than the busbar trunking manufacturer voids the manufacturer's warranty. Busbar trunking so modified is unacceptable without the written consent of the manufacturer.
 - 5 Busbars
 - 5.1 Busbars shall be of hard drawn silver-plated high conductivity copper of 99.9% purity or aluminum with copper cladding utilized Molecular Fusion technology.
 - 5.2 There shall be no bolts passing through the busbars of the busway.
 - 5.3 Each busbar shall be insulated with Class B (130°C DuPont Mylar) polyester film. Epoxy insulation is not allowed.
 - 5.4 The temperature rise at any point of the busbar trunking enclosure shall not exceed 55 degree Centigrade rise above ambient temperature when operation at rated current.
 - 6 Joint
 - 6.1 The busbar trunking joint shall be of the one-bolt type which utilizes a high strength steel bolt(s) and Belleville washers to maintain proper pressure over a large contact surface area.
 - 6.2 The bolt shall be torque indicating and at earth potential.
 - 6.3 The bolt shall be two-headed design to indicate when proper torque has been applied and require only a standard long handle wrench to be properly activated.
 - 6.4 Access shall be required to only one side of the busbar trunking for tightening joint bolts.
 - 6.5 It shall be possible to remove any joint connection assembly to allow electrical isolation or physical removal of a busbar trunking length without disturbing adjacent busbar trunking lengths.
 - 7 Plug-in Opening
 - 7.1 The connecting jaw of the plug-in unit shall plug directly onto the busbar and have full contact with busbar itself. Welded tab at plug-in busbar is not allowed.
 - 7.2 All contact on joint and plug-in opening should be silver plated copper.
 - 7.3 On plug-in busbar trunking there shall be three dead front, hinged cover type plug-in openings on each side.
 - 7.4 All openings shall be usable simultaneously.
 - 7.5 Busbar trunking shall be installed so that plugs are side mounted to permit practical use of all plug-in openings.
 - 7.6 It shall be possible to inspect the plug-in opening and busbars prior to the installation of the plug-in units.

-
- 8 Support of busbar Trunking
 - 8.1 Hanger spacing shall be noted on layout drawings and shall not exceed manufacturer's recommendations.
 - 8.2 Indoor feeder and plug-in busbar trunking shall be approved for hanger spacing of up to 3 meters for horizontally mounted runs and 4.88 meters for vertically mounted runs. Outdoor feeder busbar trunking shall be approved for spacing of up to 1.5 meters for horizontally or vertically mounted runs.

 - 9 Voltage drop
 - 9.1 The voltage drop (input voltage minus output voltage) specified shall be based on the busway operating at full rated current and at stabilized operating temperature.
 - 9.2 The three-phase line-to-line voltage drop shall not exceed 4% at full connected load.

 - 10 Fire resistance
 - 10.1 The busway shall be fire resistant - not create secondary fire outbreak - as per IEC 61439-6 in the event of fire.
 - 10.1.1 The busway shall not propagate a fire from one room to another by crossing a fire barrier wall as per IEC61439-6 clause 10.102.
 - 10.1.2 The busway shall be resistant to flame propagation as per IEC61439-6 clause 10.101.
 - 10.1.3 The busway insulating material shall be resistant to abnormal temperatures as per IEC61439-6 clause 10.2.3.2.
 - 10.2 For essential /emergency life safety circuits, which supply power to fire fighting equipment, the circuit integrity shall be maintained in the event of fire.
 - 10.3 The fire rated busway shall be tested as per standard ISO834-1 and circuit integrity shall be maintained.
 - 10.4 The busway shall not generate any toxic emission in the event of fire.
 - 10.5 The busway shall be designed such as to ensure very low smoke and zero halogen in the event of a fire to give better visibility aiding the rescue operation and enabling the EXIT path to be seen clearly for escape.

 - 11 Plug-in Unit
 - 11.1 The plug-in jaw shall be spring design composed of different metal to ensure the firm and tight contact with the busbar.
 - 11.2 The earthing contact of the plug-in unit shall always be made before that of the live conductors and the last to break during removal. And it must connect to the earth bar of busway to ensure the safety.
 - 11.3 Covers of all plug-in units must have interlocks to prevent the cover from being opened when the switch is in the ON position.
 - 11.4 Plug-in units (circuit breaker type or fusible switch type) shall be operated with visible blade quick-make and quick-break mechanism.
 - 11.5 Presence of Transparent shield shall be inside to avoid direct contact of human.
 - 11.6 The plug-in units shall be equipped with internal barriers to prevent accidental contact of fish tape and conductors with live parts on the line side of the protective device during time of wire pulling.

Schneider Busway (Guangzhou) Limited

Postal address
85 Jun Ye Road, Northern Part of Eastern Section
of Guangzhou Economic & Technological
Development District, Guangzhou
510530, PR China

Tel: (86) 20 2820 2828
Fax: (86) 20 2820 2884
[Http://www.schneider-electric.com](http://www.schneider-electric.com)

As standards, specifications and designs change from time to time, please ask for confirmation of the information given in this publication.



This document has been printed on ecological paper